

**SOLAR HEATING
OF COMMERCIAL GREENHOUSES
KUBE PAK INC.**

By

David R. Mears

William J. Roberts

John P. Cipolletti

Prepared By

**Department Of Biological And
Agricultural Engineering**

N.J. Agricultural Experiment Station

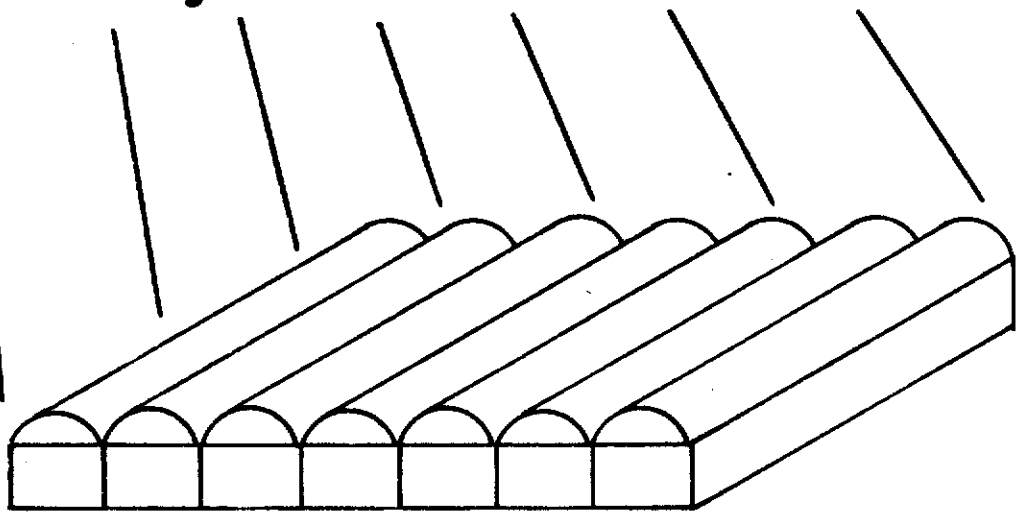

SOLAR HEATING OF COMMERCIAL GREENHOUSES

Kube Pak Garden Plants, Incorporated

Final Report, Phase V

By

David R. Mears, William J. Roberts, and John P. Cipolletti

June 1980

Revised May 1981

Contract No. EG-77-C-05-5454

Prepared For

**United States Department of Energy
Division of Conservation and Solar Energy**

Prepared By

**Department of Biological and Agricultural Engineering
Cook College
New Jersey Agricultural Experiment Station
Rutgers University
New Brunswick, New Jersey 08903**

PROJECT AND FUNDING ACKNOWLEDGMENTS

This work was performed as a part of NJAES Projects No. 03130 and 03932, supported by the New Jersey Agricultural Experiment Station, The US/DOE, Kube Pak Garden Plants, Inc., Stauffer Chemical Co., Monsanto Commercial Products Corp., The Van Wingerden Greenhouse Co., and X. S. Smith, Inc. NJAES Research Report R03932-02-81.

NOTICE

This report was prepared as an account of work sponsored by the United States government. Neither the United States Department of Energy, nor any of its employees, nor any of its contractors and subcontractors, or their employees, makes any warranty, express or implied, or assumes any legal liability or responsibility for the accuracy, completeness, or usefulness of any information, apparatus, product, or process disclosed, or represents that its use would not infringe privately owned rights.

DISCLAIMER

Reference to commercial products or trade names is made with the understanding that no discrimination or endorsement is intended or implied.

FOREWARD

This document is the final report on the Phase V activity of DOE Contract EG-77-C-05-5454. It describes the design, construction and performance of a solar heating facility in a commercial greenhouse at the Kube Pak Garden Plants Corporation, Allentown, New Jersey. The work was performed by the Biological and Agricultural Engineering Department, New Jersey Agricultural Experiment Station, Cook College-Rutgers University, New Brunswick, New Jersey.

The system is based upon research conducted at The New Jersey Agricultural Experiment Station supported in part by ARS Agreement 12-14-7001-550. This research was directed toward Phases I, II and III of the solar greenhouse heating program. The majority of the support for this project has been provided by the Kube Pak Corporation. In addition to resources provided by DOE and the New Jersey Agricultural Experiment Station substantial material support has been provided by the Stauffer Chemical Company, Monsanto Commercial Products Corporation, the Van Wingerden Greenhouse Company and X. S. Smith, Incorporated.

More complete details of the design and construction of the facility are contained in the Phase IV final report of December 1978. The results of this program have also been extensively reported to the public in meetings and in technical and popular articles. A partial listing of publications and presentations arising from this demonstration project and related research at Rutgers is contained in this report.

It is important to note that there has been substantial technological spin-off from this project. In particular:

- Movable curtain insulation systems, which are an integral part of the system developed by this project, are being widely installed in commercial greenhouses.

- Warm floor systems for greenhouses are becoming increasingly adopted commercially and a number of alternative systems for providing warm floors have been developed, largely as a result of this program.

- The flooded warm floor concept has been successfully applied to the utilization of waste heat from a power plant.

- A residential application of the flooded warm floor has been developed and demonstrated.

TABLE OF CONTENTS

Foreward	ii
List of Tables	iv
List of Figures	v
Abstract	1
Summary of Phase IV Report	2
Introduction	4
System Components	5
Solar collectors	6
Floor heat exchanger/storage	9
Curtain insulation system	14
Auxiliary heating system	21
System Performance	25
System Economics	38
Further Commercial Applications	39
Technological Spinoff	40
Conclusions	41
Future Considerations	42
References	43
Publications Resulting from Solar Research at Rutgers	45
Manual for Collector Construction	56
Manual for Floor Construction	67

LIST OF TABLES

Table 1	Curtain Heat Transfer Values	18
Table 2	Curtain Physical Ratings	20
Table 3	Final Curtain Rankings	21
Table 4	Performance during Fall 1978 Poinsettia Crop	27
Table 5	Nine Week Energy Totals for Fall 1978 Season	27
Table 6	Performance during Spring 1979 Bedding Plant Crop ..	28
Table 7	Four Week Energy Totals for Spring 1979 Season	28
Table 8	Performance during Fall 1979 Poinsettia Crop	29
Table 9	Seasonal Energy Totals for Fall 1979	30
Table 10	Performance during Spring 1980 Bedding Plant Crop ..	30
Table 11	Six Week Energy Totals for Spring 1980	31
Table 12	Calculated Energy Consumption of Various Structures Based on Fall 1979 Data	36
Table 13	Seasonal Energy Totals Comparing Various Structures.	36

LIST OF FIGURES

Fig. 1	Schematic Cross Section of Solar Heated Greenhouse .	5
Fig. 2	Schematic Plan of Floor Water Flow	6
Fig. 3	Cross Section of Fixed Solar Collector	7
Fig. 4	Theoretical and Actual Collector Performance	8
Fig. 5	Insolation and Collected Energy, February	9
Fig. 6	Insolation and Collected Energy, March	10
Fig. 7	Porous Concrete Floor Cross Section	10
Fig. 8	Temperature/Time Profiles at Various Depths in the Porous Concrete	12
Fig. 9	Thermal Transmittance of Greenhouse, Reemay Curtain vs No curtain	15
Fig. 10	Thermal Transmittance of Greenhouse, Double Knit Curtain vs Revere Curtain	15
Fig. 11	Thermal Transmittance of Greenhouse, Black Poly Curtain vs Aluminized Vinyl Curtain	16
Fig. 12	Thermal Transmittance of Greenhouse, Black Poly over Reemay Curtain vs Reemay over Black Poly Curtain ...	16
Fig. 13	Thermal Transmittance of Greenhouse, Reinforced Poly Curtain vs New Formulation Black Poly Curtain	17
Fig. 14	Thermal Transmittance of Greenhouse, Black Poly 97% Shade Curtain vs Foylon Curtain	17
Fig. 15	Chart of Curtain Type vs Mean U value	19
Fig. 16	Effects of Various Curtain Types on Heat Loss	21
Fig. 17	Temperatures for 10 cm Potted Poinsettia in Raised Pots	31
Fig. 18	Temperatures for 10 cm Potted Poinsettia in Pots on the Floor	32
Fig. 19	Temperatures for 25 cm Potted Poinsettia	32
Fig. 20	Temperatures while Germinating Seed in Floor Flats .	33
Fig. 21	Temperatures with Spring Bedding Plants 2/28-3/1 ...	33
Fig. 22	Temperatures with Spring Bedding Plants 3/18-3/19 ..	34
Fig. 23	Weekly Energy Totals for Fall 1979	35
Fig. 24	Weekly Energy Totals for Spring 1980	35
Fig. 25	Calculated Energy Required from Fossil Fuel for Fall 1979 for Several Systems	37

ABSTRACT

A 0.54-hectare commercial greenhouse was constructed as a demonstration project. The facility built at Kube Pak Garden Plants, Inc. of Allentown, New Jersey was composed of several elements that constitute a solar heating system developed at Rutgers University. These components include a flooded floor storage/ heat exchanger system, insulating curtains, plastic film solar collectors, and a back-up heating system. The project objectives included determining the feasibility of constructing the system on a large scale, evaluating the thermal performance of the system and individual components, and determining whether or not the facility could be effectively operated and maintained.

Results clearly indicated that the system could be effectively and economically constructed and operated on a large scale. The large solar collector field operated as predicted by theoretical projections based on testing of smaller units and provided more than the projected 25% contribution to the energy budget on various occasions. The curtain insulation system performed well, a reduction in the base energy requirements of the structure of up to 50% being recorded with some curtain material combinations tested. A change in management practice encouraged by the warm floor allowed a further reduction in the greenhouse energy load. Fuel consumption of the greenhouse was reduced considerably by the system. The amount of fuel oil consumed was reduced by 45% the first year, 73% for the fall 1979 season and 69% for the spring 1980 season, when compared with a neighboring check section.

Further research should be done with a homogeneous curtain system composed of the best material tested. Analysis of the data collected in the fall 1979 heating season indicates that if all the insulating curtains had been of the best type tested, the total energy savings would have been 87%. Economic analysis indicates that at \$10 per GJ for energy, total system savings in the fall 1979 and spring 1980 season totaled \$33,340, which was 23% of the \$143,600 construction cost. Had the best performing curtain systems been used throughout, that savings would have been increased to 27% of total system cost. Also cultural practices that fully exploit the advantages of a warm floor heating system need to be determined for more crops.

SUMMARY OF PHASE IV REPORT

The impact of rising fuel costs on the greenhouse industry has been well documented in numerous references. Also, the uncertainty regarding the availability of fuel at any price and the probable rate at which prices will rise in the future are disturbing to many operators. The role to be played by solar energy in greenhouse heating is not yet completely clear.

Polyethylene greenhouses have become more popular and functional since the successful development of the double covering system using low pressure air to separate two film layers, as reported by Roberts in 1969. There are more than six manufacturers of large multispans greenhouses using this technique developed at Rutgers in 1965. One of the manufacturers has sold more than 200 acres of greenhouses in 3-1/2 years and another more than 175 acres in 5 years, including 23 acres overseas.

Research at Rutgers has been geared to the application of solar energy for heating these low-initial-cost, highly efficient greenhouses. The research has involved design of low-cost collectors, efficient and functional heat storage, the reduction of heat losses from these double film greenhouses and the use of new designs for heating greenhouses with low-temperature water.

In 1972 work was started in New Jersey on a practical means of insulating greenhouses at night by utilizing mechanically operated curtains previously developed for photoperiod control. The results of this work were first presented publicly by Mears, et al. in 1974. Systems to reduce the rate of heat loss in greenhouses are beneficial when used in conjunction with any heating system. However, the benefits of insulation are even more important when solar heat is used, as solar systems tend to have relatively high initial costs per unit heating capacity. Also, reduced heating rates enable solar components to operate at lower temperatures and higher relative efficiencies.

In 1974 work was initiated in Bradenton, Florida (Baird, et al., 1976), on a complete greenhouse solar heating system based on the type of components that are commercially available. These included flat plate solar collectors, an external insulated storage tank, forced, convection water-to-air heat exchangers and automatic controls. Operation of this system over several heating seasons provided useful information on the operating characteristics of the several components and their interactions. It has been shown that a properly designed system will operate at relatively low temperatures, that the storage and heat exchange capacity must be large and that component costs must be markedly reduced.

Work on low-cost components and on the integration of the functions of the solar components with basic greenhouse structural features has been conducted at New Brunswick, New Jersey. The availability of large storage capacity and large heat transfer surface reduces the temperature requirements of the solar collectors. Therefore, low-cost plastic film collectors have been developed that exploit this circumstance and appear to be more economical to operate than conventional flat plate collectors.

Large heat storage capacity and heat transfer surface can be achieved by using a plastic-lined gravel bed covered with a porous concrete cap for the

greenhouse floor. Water is stored in all the void spaces in the gravel and the entire floor becomes a heat exchange surface. This technique ties in well with two developing practices in many greenhouses: putting heat pipe in concrete floors to control soil temperature and using porous concrete floors to eliminate standing water problems.

Additional heat transfer surface can be provided by raising a vertical curtain consisting of a plastic film folded over a water supply manifold pipe. Warm water flowing down between the plastic films warms the greenhouse and returns to storage through the porous floor with negligible evaporation.

The results of early research were very encouraging and it was therefore decided that a full-scale commercial installation should be built and evaluated. A proposal was developed for installation of the components of the Rutgers system in a 7200 ft² section of a multibay gutter-connected greenhouse at Kube Pak Garden Plants, Inc., Allentown, New Jersey. This proposal was selected by DOE for support as a demonstration project. By the time the contract was to commence, the cooperating growers had developed plans to construct an addition at the end of another greenhouse. This addition was to consist of 10 gutter-connected bays, each 20 ft wide by 290 ft long with a center walkway, for a total floor area of 58,000 ft². This development presented the attractive opportunity of constructing the solar demonstration section as a part of the new addition. It was anticipated that new construction would greatly simplify the work, especially of the floor storage system. The expansion of the project to 58,000 ft² was undertaken with the support of the cooperating growers, the university and industry. There was no increase in support from DOE beyond that for the 7200 ft² in the original proposal. It was the cooperation of those cited and the economies of scale that made this increased project possible.

INTRODUCTION

A greenhouse epitomizes the idea of energy-intensive agriculture, its purpose being the creation of an artificial environment that may differ radically from the surrounding environment. In recent years, the rising costs of fossil fuels have dealt a blow to the economic viability of the traditional commercial greenhouse. Therefore research in the areas of conservation and alternative energy sources is not only timely, but vital. The two topics are closely related, since alternative energy sources may begin to become attractive only after employment of conservation practices.

At the Biological and Agricultural Engineering Department of Rutgers University, greenhouse energy utilization has been a subject of interest since the early 1960's; an interest that culminated in the development of the air-inflated, double polyethylene greenhouse (Roberts, 1969), which still stands as the most energy-efficient commercial structure available on the market today. Conservation of energy was therefore the first step taken, with the double covered plastic house showing a one-third reduction in energy consumption compared with a standard glass structure.

Mechanical systems originally designed for shading (Roberts, 1970) have been shown to reduce the convection and radiation losses of a greenhouse by a number of authors. Work at Rutgers showed a potential savings of over 50% when a black plastic blanketing system was used at night as a thermal blanket in a glass house. Simpkins et al. (1975) reported on the merits of various curtain materials and curtain orientations when used to reduce heat loss in an environmental chamber and in a prototype greenhouse. He found that the optimal configuration for the insulating system held the curtain in a horizontal position, eave to eave across the greenhouse. Materials aluminized on at least one side performed better than non-aluminized materials, particularly if the aluminized side faced the colder temperature.

Low-cost solar collectors made of two greenhouse grade polyethylene tubes sandwiching a black polyethylene absorber were originally reported by Mears and Baird (1976). Later, Kendall et al. (1979) presented a detailed theoretical study of the performance of these collectors with experimentally determined collector performance parameters. Both papers showed acceptable collection efficiencies at low temperature differences between the collector absorber and the surrounding air.

The use of a large water storage area located under the greenhouse as a heat exchanger was suggested by Mears et al. (1974). The large storage and heat exchange area was needed for the optimal use of the low temperature solar collectors. The storage system consisted of a vinyl liner containing a rock aggregate mass, with 50% pore space for storing water, capped by a porous concrete layer (Roberts et al., 1976). This warm floor storage/heat exchanger proved to be ideally suited to the solar collectors. Additionally the porous concrete floor provided an easily maintained growing surface, which accommodated carts and automatic watering systems. Location of the heat source below the growing medium allowed the heat to be distributed evenly with a lower source temperature (Roberts et al., 1979), a lower air temperature and substantial energy savings. To further enhance the operation of the system, a heat exchanger for operation at low temperature differences was needed. An inexpensive design utilizing plastic film was

developed at Rutgers to increase the effective heat transfer area for more effective utilization of the low-quality heat in storage. This work including a complete system description, was reported by Roberts et al. (1976).

Installed in several small research facilities, this system permitted a 53% contribution by solar energy to the total energy budget in the first year of operation (Mears et al., 1977).

The Kube Pak project was undertaken to determine the feasibility of applying the system described above to heat a large commercial greenhouse. Mears et al. (1978) reported in detail on the development and construction phases of this facility. The control system for this greenhouse has also been reported (Roberts and Mears, 1978). A brief description of the system and its control logic follows, for more detailed information refer to the aforementioned reports.

A 0.54-hectare, double-covered, air-inflated greenhouse was constructed in 1977-78 at Kube Pak Garden Plants, Inc. in Allentown, New Jersey (shown schematically in Fig. 1). The floor is a composite and serves as the primary heat exchange surface and thermal storage. Movable, automatic, horizontal thermal blankets have been installed using a variety of materials. The floor water is heated by 1000 square meters of plastic film solar collectors adjacent to the greenhouse. Fossil fuel boilers provide heat to the greenhouse environment when needed and also serve as a back-up source for the floor system (see Fig. 2). The greenhouse heating system has been divided into two zones that could run independently if desired.

- | | |
|----------------------------|-----------------------------------|
| 1 AIR INSULATED GREENHOUSE | 6 OVERHEAD BACK-UP HEATING SYSTEM |
| 2 MOVABLE INSULATION | 7 PUMP TO SUPPLY COLLECTOR |
| 3 GRAVEL/WATER STORAGE | 8 PLASTIC SOLAR COLLECTOR |
| 4 PLASTIC LINER | 9 GRAVITY RETURN |
| 5 POROUS CONCRETE FLOOR | |

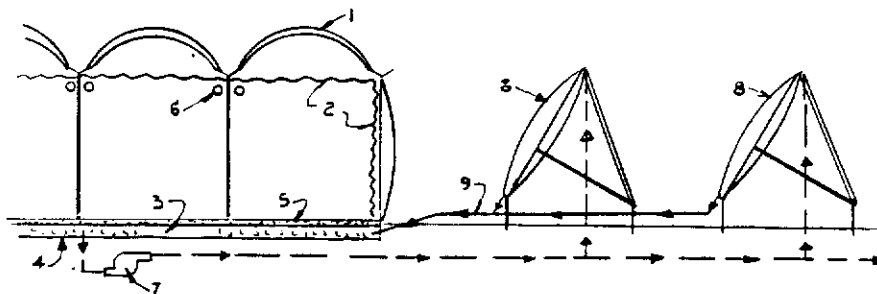

Fig. 1 Schematic Cross Section of Solar Heated Greenhouse

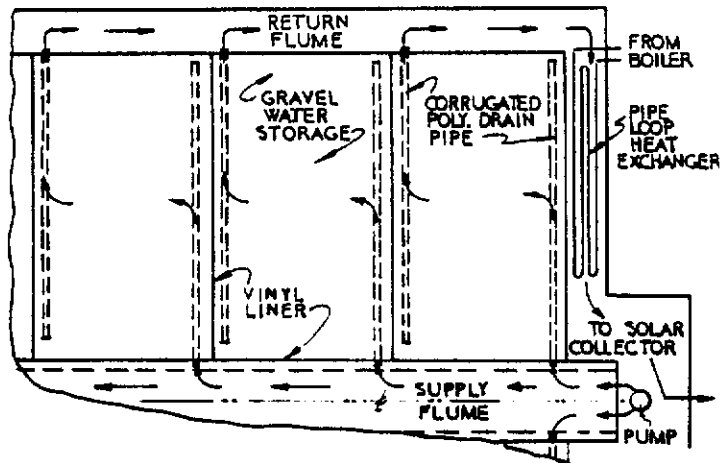

Fig. 2 Schematic Plan of Floor Water Flow

Greenhouse temperature control is maintained by time clocks and thermostats. The thermal blanket system operates automatically and is controlled by an adjustable time clock. The overhead circulator heating system is controlled in each section by two thermostats set for varied control of day and night temperatures. The solar collectors are controlled by a differential thermostat measuring both the storage and collector plate temperatures. Thermostats are located in the floor system of each section to control the auxiliary floor heat exchangers, which are connected to the oil-fired boilers. Circuit logic within the control system overrides the auxiliary floor heating system if the differential controller activates the solar collector pump. A small pump continuously agitates floor water to eliminate sampling errors by the floor thermostats. The system has been in automatic operation for 3 years.

SYSTEM COMPONENTS

Solar Collectors

The solar collectors operating at Kube Pak are a low-cost plastic film design. The collectors are composed of six layers of plastic film supported by framing. Four layers of 6-mil, clear, greenhouse grade polyethylene form two inflated outer layers, which provide structural stability and some insulation. Sandwiched between the two outer layers are one layer of black polyethylene and one layer of black polypropylene shade mesh (Fig. 3). These two black layers form the absorber plate. The polypropylene is added to enhance water spreading as it trickles down from a header pipe in between the upper clear tube and the absorber face on its way to the collecting gutter. The shade mesh also inhibits the fusing of the black absorber to the front clear layer under extreme heat conditions, such as are encountered in the event of stagnation.

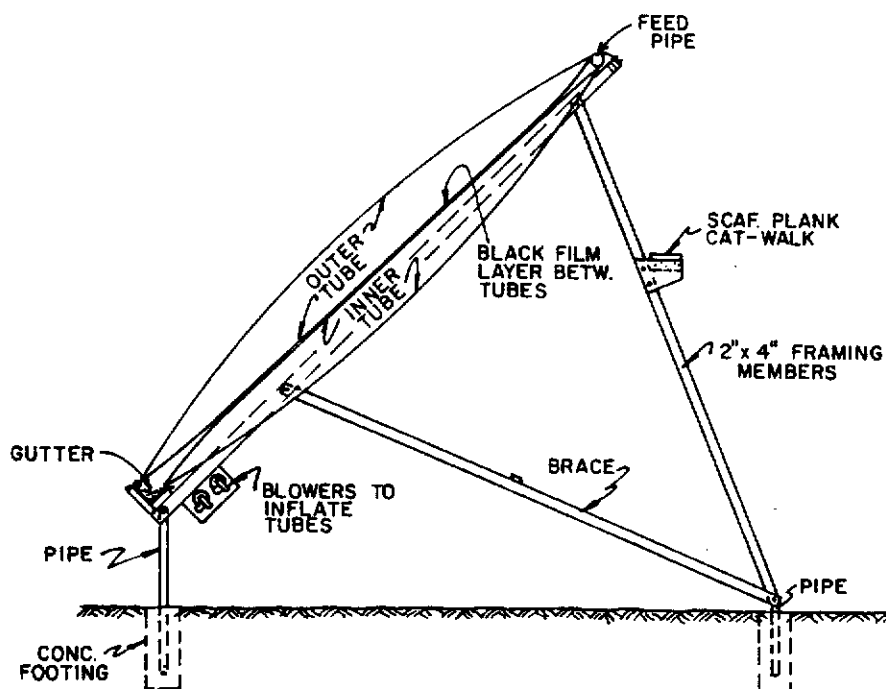

Fig. 3 Cross Section of Fixed Solar Collector

Using the relationship developed by Hill and Kusada (1974) among incident solar energy, energy collected, temperature of the working fluid, and ambient air temperature, Kendall et al., (1979) developed a theoretical performance line for this collector design. Experimental performance was then evaluated and compared to theory. The relationship and determined values are as follows:

$$\eta = Q_c / Q_s = \tau \alpha U (T_c - T_a) / Q_s$$

where:

- η = efficiency
- Q_c = energy collected
- Q_s = incident solar energy
- $\tau \alpha$ = constant relating transmissivity of the cover plate and overall absorptance of the surface = 0.80
- U = overall heat loss coefficient for the collector = 16.2 W/m²K
- T_c = average water temperature flowing through the collector
- T_a = ambient air temperature

The first experiment involving the solar collectors was designed to determine if the collectors were performing as predicted by the relationship obtained by Kendall in studies of similar collectors. To monitor the water temperatures, copper-constantan thermocouples were placed in the inlet pipe to the collector field and the outlet flume from the collector field. Air temperature was measured shielded atop a weather station at an elevation of 9 meters. Incident solar energy flux was measured directly

with a Dodge Electronics solarimeter, which generated a millivolt output per langley. All these outputs were connected to a DORIC 230A data acquisition system. Total water flow was obtained by a CORAD integrating flow meter. An event recorder on the data acquisition system recorded operation time, so that a flow rate could be determined for the experiment.

To determine Q_c , a relationship presented in Gebhart (1961) for determining heat gained or discharged by a fluid was used. The relationship is:

$$q = \dot{m}c_p(T_o - T_i)$$

where:

- q = heat flux
- m = mass flow rate
- T_o = outlet temperature
- T_i = inlet temperature
- c_p = specific heat of the fluid

The data presented graphically in Fig. 4 show the theoretical (line) and actual (o) performance of the collector field. Points designated with a 'o' are obtained by applying the formulae stated above to the recorded data. Since the Y axis is efficiency (Q_c/Q_s) and the x axis is $(T_c - T_a)/Q_s$, the slope of the theoretical regression line is the value stated for U and the intercept is $\tau\alpha$. The 11 observations shown were all taken at the same time of day, approximately solar noon, on 11 different days over a 6 month period of operation.

A regression analysis of the reported data yields the following constants:

$$\begin{aligned} \tau\alpha &= 0.73 \\ U &= 12.6 \text{ W/m}^2\text{K} \\ r^2 &= 0.6 \end{aligned}$$

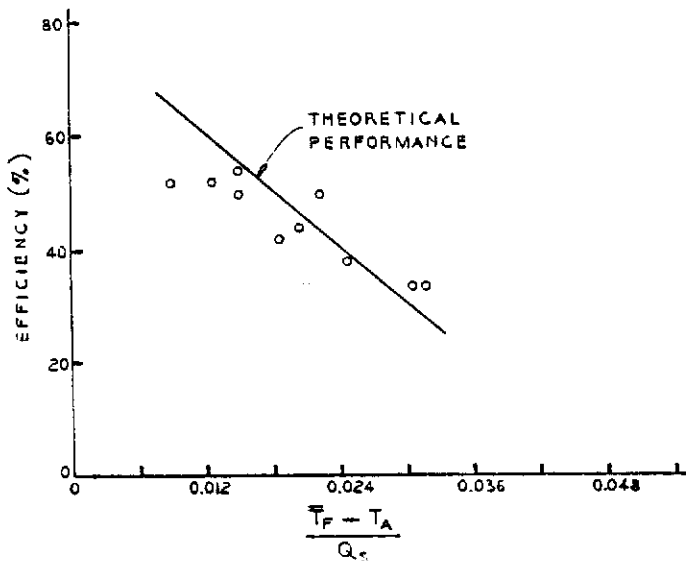

Fig. 4 Theoretical and Actual Collector Performance

A possible explanation of these values is as follows. Most of the values occurring toward the right of the presented graph were taken during the earlier months of the testing period and the values toward the left of the graph were taken at the end of the test period. These later values were

subject to a gradual decay in the cover plastic and accumulation of dirt, thus the transmissivity of the cover decreased. This causes these values to be lower than predicted. The lowering of these values in general had more influence than the varying weather conditions and forced a flattening of the regression line, resulting in a lower value than predicted for both constants. The decay also resulted in a slightly curvilinear aspect in the data and a low correlation coefficient. The data do fall close to predicted values however, with a mean departure of 8%.

In Figs. 5 and 6, the daily performance of the collector field is presented for two conditions. Figure 5 shows the performance on a cold day in February when the mean fluid temperature was much higher than the ambient temperature. Figure 6 is again the daily performance of the field, however here the ambient temperature was much warmer (data from early March). Both graphs show data taken when the plastic was slightly degraded and dirty after a full year of operation. Points plotted are mean values determined for 1-hour time increments (x-axis). Points designated with open circles are values for the incident solar flux (W/m^2). Points designated with solid dots are the corresponding values for useful energy collected per square meter (W/m^2). Daily efficiency for the colder day was lower than for the mild day as expected. The corresponding daily efficiencies are 28% and 47%, respectively, a difference that serves to illustrate the need for using a low temperature storage in these collectors. The poor insulation value associated with these collectors is the reason for the large change in efficiency over the season. The viability of these solar collectors requires maintaining a small temperature difference between the storage water temperature and the outside ambient temperature. In designing a system using these collectors, one should consider the measured decay of 15% in performance due to plastic degradation and dirt accumulation over the material's useful life of 2 years. The economics of changing the outer plastic layer each fall in order to start each heating season with a clean cover has not been determined. Due to the extremely low cost of this cover material, changing it each fall could be an attractive strategy.

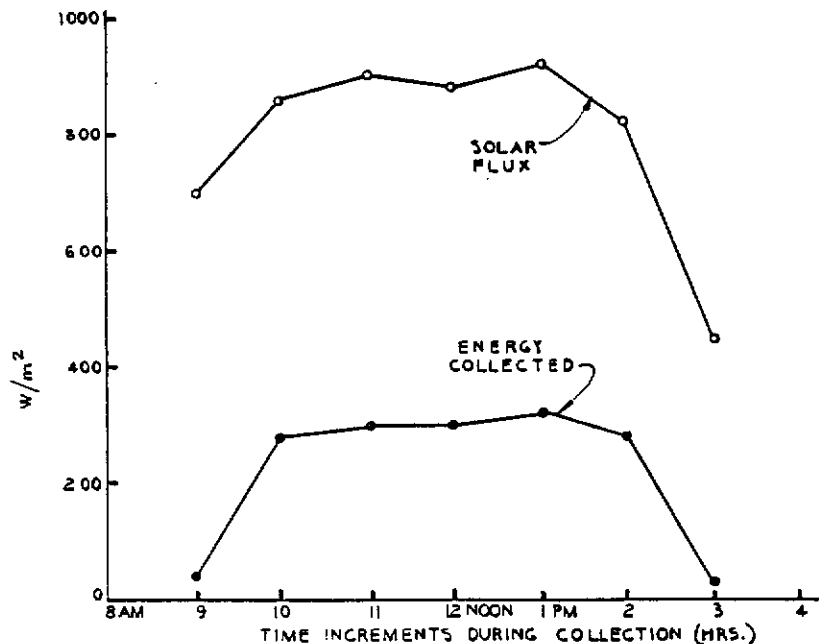

Fig. 5 Insolation and Collected Energy, February

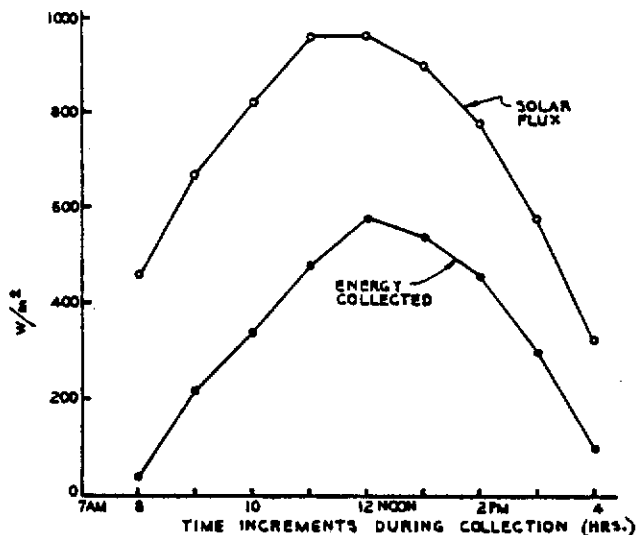

Fig. 6 Insolation and Collected Energy, March

Floor Heat Exchanger/Storage

The composite floor of the greenhouse (Fig. 7) acts as both a heat exchanger to provide heat input to the greenhouse and as the storage volume for the solar collection system. The floor is isolated from the ground by a layer of styrofoam insulation. On top of the insulation and containing the storage is a vinyl liner. The storage area is filled with rock aggregate for support, which has a 50% pore space (500 l/m³ of water). The floor is capped with porous concrete, which provides a firm working surface that will allow water to drain through.

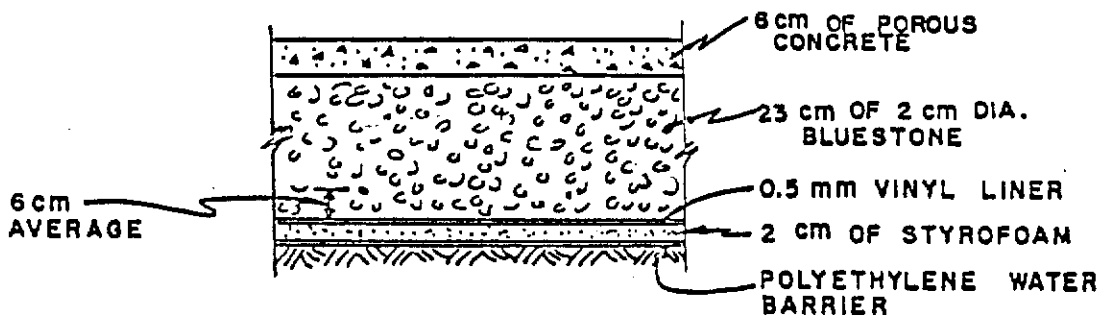

Fig. 7 Porous Concrete Floor Cross Section

As a heat exchange surface, the floor worked within two extremes. In one extreme, the floor operated covered with bedding plants. At the other extreme, the floor operated bare during the winter period between seasons. To evaluate the floor operation under these conditions, the data were scanned to locate a time period when the greenhouse and floor temperatures remained steady and the auxiliary heaters were not in operation. In this condition, all the greenhouse heating was accomplished by the floor system. To obtain a combined heat transfer coefficient, or U value, only the heat flux and the temperature difference between the floor and greenhouse are needed. With these values, the following relation from Gebhart (1961) for steady state heat transfer can be used:

$$Q_f = U_f A (T_f - T_g)$$

where in this case:

- Q_f = the energy provided by the floor
- U_f = the overall heat transfer coefficient
- A = the total floor area available for heat transfer
- T_f = the storage temperature
- T_g = the greenhouse air temperature

The temperatures in question were measured with copper-constantan thermocouples. Air temperatures used in the calculations represented an average of 10 thermocouple locations throughout the greenhouse. The floor temperature also represents an average temperature computed from eight locations. Storage temperature is the temperature of the water in the storage. Energy transfer was determined indirectly in the following manner. An overall heat transfer coefficient for the greenhouse cover was determined for a control greenhouse of similar construction in the same range. This coefficient was used to determine the heat loss of the structure during the time of the experiment. Measurements were made at night after ample time had passed to eliminate transient heat flows. Since a steady-state condition had been reached, the heat loss from the structure was exactly compensated for by the floor energy input.

A small portion of the floor was not composed of porous concrete. The walkways were of standard concrete mix and an overall heat transfer coefficient, determined for this material by Cipolletti, (1978) of $4.5 \text{ W/m}^2 \text{ K}$ was used in the analysis.

The results obtained from these two extremes represent a range in which the floor system operates. Depending on the crop grown and cultural practices, the floor surface is covered to varying degrees. Since it is common to grow plants at a relatively high density actual operation of this floor is more likely to occur at the lower end of this range. The values of this range are:

$$U_{\text{covered}} = 5.1 \text{ W/m}^2\text{K} \text{ to } U_{\text{bare}} = 8.8 \text{ W/m}^2\text{K}$$

It should be mentioned here that during the experiments, losses to ground were negligible, since the floor system was insulated and the soil under the storage had increased in temperature over time approaching that of the storage (as a result of early fall heating). Thus the driving force for heat transfer was relatively low (3% of the flux into the greenhouse).

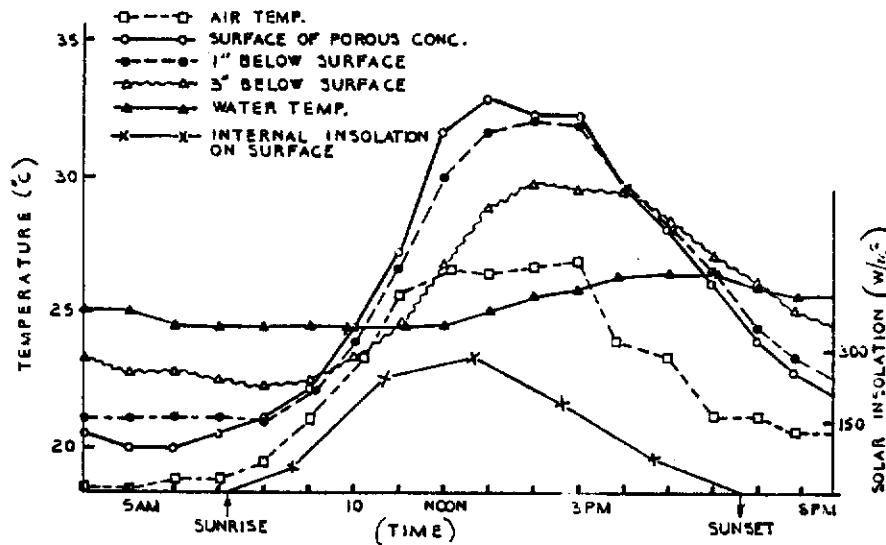

Fig. 8 Temperature/Time Profiles at Various Depths in the Porous Concrete

Another aspect of the floor system to be considered is its thermal mass. In this system various components of the floor system contribute to the thermal mass. Figure 8 shows the changes in temperature at various depths in the porous concrete over time. Since the upper portion of the porous concrete exhibited wide fluctuations in temperature due to passive solar gain, it is useful to separate the porous concrete cap from the underlying storage when evaluating thermal mass. Henceforth in these discussions, 'thermal mass' of the storage will refer only to the volume below the porous cap. The cap and above are considered as part of the thermal mass of the greenhouse structure.

To determine the thermal mass of the storage system, the auxiliary floor heating system was used. By knowing the heat input of these heat exchangers to the floor, and observing the rise in floor temperature over time, the thermal mass could be determined. Evaluation of the heat input from the auxiliary heating system is the subject of a later section. The experiment was conducted during the day when greenhouse air temperatures were greater than the floor temperatures, so that there was no net loss from storage. It was found that 4.9 GJ per degree centigrade rise in floor temperature was used. Thus the thermal mass for this floor system, as it was used during these experiments, was 0.9 MJ/m²K. This corresponds to three quarters of what would be expected if the entire floor volume were water instead of the water-rock combination. This value was subject to change over the period of use since plant watering and sporadic leakage changed the amount of water in storage.

Data pertaining to the passive gain of the floor were obtained by the use of an internal horizontal solarimeter and a net radiometer. By using the internal horizontal solarimeter coupled to the data acquisition system, the

actual solar flux passing into the greenhouse was measured directly. The net radiometer positioned over the floor to measure the solar flux that was absorbed by the floor was also linked to the acquisition system. The instrument compared the incoming energy incident on its upper hemisphere with the energy incident on the lower hemisphere. The energy incident on the lower hemisphere was the total energy reflected from the porous floor. Thus the net radiation reading was the total energy absorbed by the floor. The values from both instruments were recorded every 10 minutes for an entire day on three different occasions. Values were then totaled for the day to arrive at a daily figure for both the total incident energy and the energy absorbed by the floor. By comparison of these two figures, a total hemispherical absorptivity for the floor system was determined. Individual instantaneous values varied between 20 and 32 % during the day. The average value per day for a bare floor was 26%. Total absorptivity for a floor with a full plant canopy was 65%. The utility of this number for determining passive heat gain is not clear. Although the photosynthetic process does not use more than 3% of the incident light energy (Walker, 1965), plant transpiration is a significant drain on this energy input accounting for about two-thirds of the incoming energy.

A second test was conducted to check the value obtained from the net radiometer experiment for the bare floor absorptivity. A section of floor was instrumented with thermocouples placed at varying depths. The change in temperature versus time was observed at these locations, along with greenhouse and water temperatures (see Fig. 8). The temperature at the surface of the concrete was observed to reach a point of thermal stability. At this point the incident solar energy absorbed would equal exactly the energy lost from the surface by natural convection. A convection coefficient was determined to be 5 W/m²K (from an empirical relation obtained from the ASHRAE handbook, 1965), and the corresponding absorptivity was found to be 21%.

By using this absorptivity and calculated convection coefficient, the heat capacitance per cubic meter of porous concrete was determined. A section of concrete removed from another greenhouse was measured and weighed to determine the density of the sample. From the thermocouples in the floor, the change in temperature versus time and incident solar flux were recorded. In this case conservation of energy determines that the absorbed solar flux had to equal the energy lost from the surface by convection plus the energy stored or released from the concrete mass. At a point during the day, shown in Fig. 6, the upper stratum of concrete was losing energy only in one direction, through convection from the surface. Using the change in temperature at this point, along with the incident absorbed solar flux and convective loss, a value for the heat capacitance per cubic meter could be solved for directly from the following formula:

$$\alpha Q_s A = h A (T_f - T_g) + m_f c_p dT/dt$$

where:

- α = floor absorptivity
- Q_s = solar flux
- A = floor area
- h = floor heat transfer coefficient
- T_f = floor temperature
- T_g = air temperature

m_f = floor mass
 c_p = floor specific heat
 dT/dt = change in floor temperature over time

From this equation the value for $m_f c_p$ was found to be 1543 kJ/m²C which translates to a c_p of 835.9 J/kg K when the measured density of the porous concrete was used. Kreith and Kreider (1979) list the c_p of concrete as 837.4 J/kg K, a figure that agrees with the above to within 2% and is close enough to be considered identical.

The warm floor in this house was a benefit for the grower for a number of reasons. When growing on a typical floor, the cooler ground temperature necessitates maintaining a high air temperature to assure a minimum soil temperature for root growth. This problem is eliminated in this system by turning the floor into a heat source. As a result, management practices could be altered to become more energy conservative.

Since the crop with a warm root zone will grow faster, seed germination was started 3 weeks later than normal for the spring crop, eliminating greenhouse operation during the coldest part of the year. Also during the fall 1979 and spring 1980 seasons, air temperatures were lowered gradually from 18 to 10°C. This resulted in a lower base energy consumption for the structure. Reduction in the overall energy load of up to 32% was attributable to this management change.

Curtain Insulation System

The horizontal curtain insulation system was evaluated to determine the merits of different materials. Each curtain material was evaluated thermally by monitoring the temperature in the attic above the curtain and the greenhouse temperatures below the curtain. One problem encountered with this insulation system was a collection of condensed water on the top of the curtains. Each curtain was thus evaluated for water porosity and maintenance of physical integrity. Each material was also evaluated for ease of installation and mechanical characteristics while functioning. At the conclusion of this section, the materials are ranked according to these three evaluations. In determining this ranking, thermal properties are given the greatest weight, since this property was the most objectively determined and most significant to the research.

To determine the thermal properties of the various materials, the heat flux from the greenhouse had to be determined. The greenhouse was operated for a time without the curtain system operating. Knowing the heat input during this period allowed the computation of an overall heat transfer coefficient (4.3 W/m²K). This value was then assumed to be a valid heat transfer coefficient for the greenhouse roof. This enabled the calculation of heat loss through the greenhouse roof using attic and ambient temperatures. This heat loss and the temperature difference between the greenhouse and outside ambient temperatures was then used to determine an overall heat transfer coefficient for the curtain-roof combination.

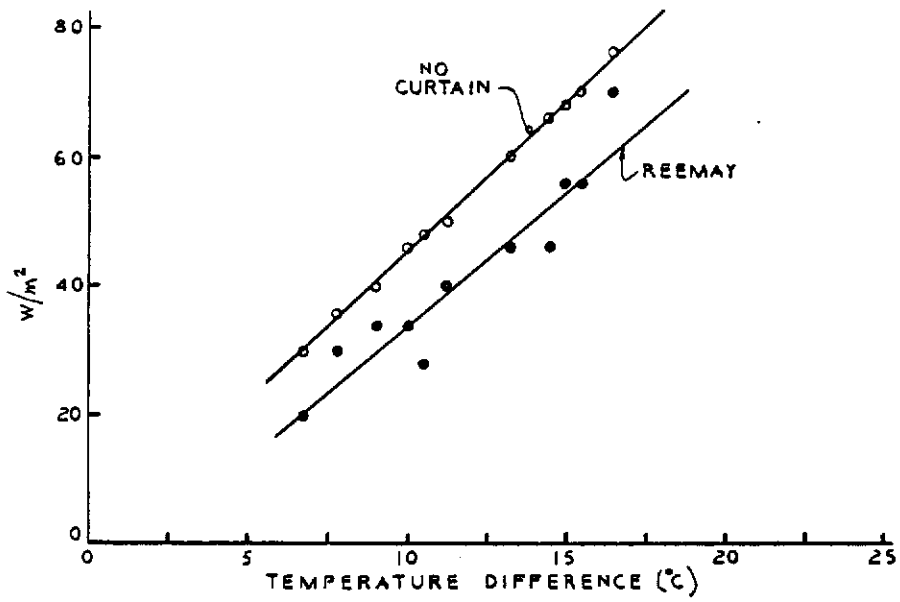

Fig. 9 Thermal Transmittance of Greenhouse, Reemay Curtain vs No Curtain

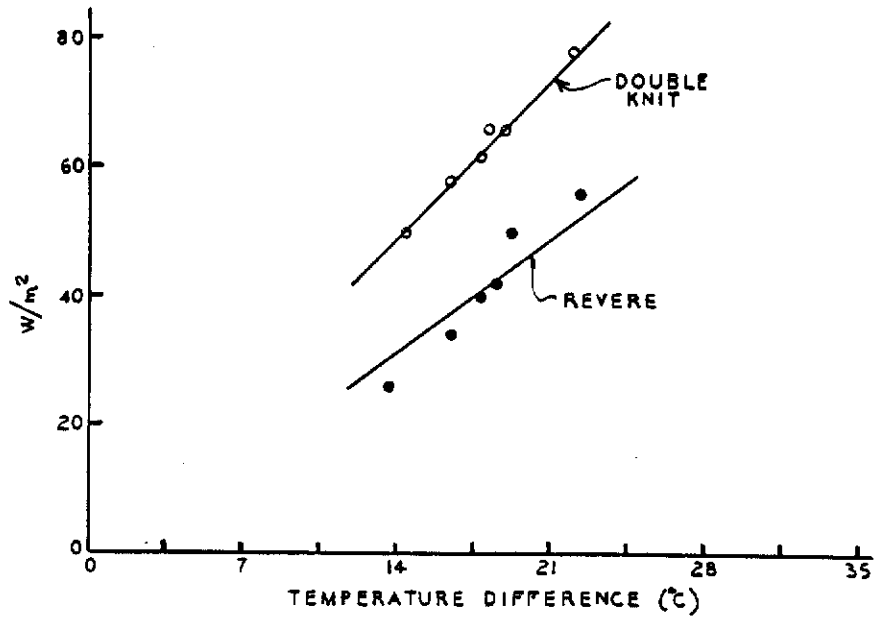

Fig 10. Thermal Transmittance of Greenhouse, Double Knit Curtain vs Revere Curtain

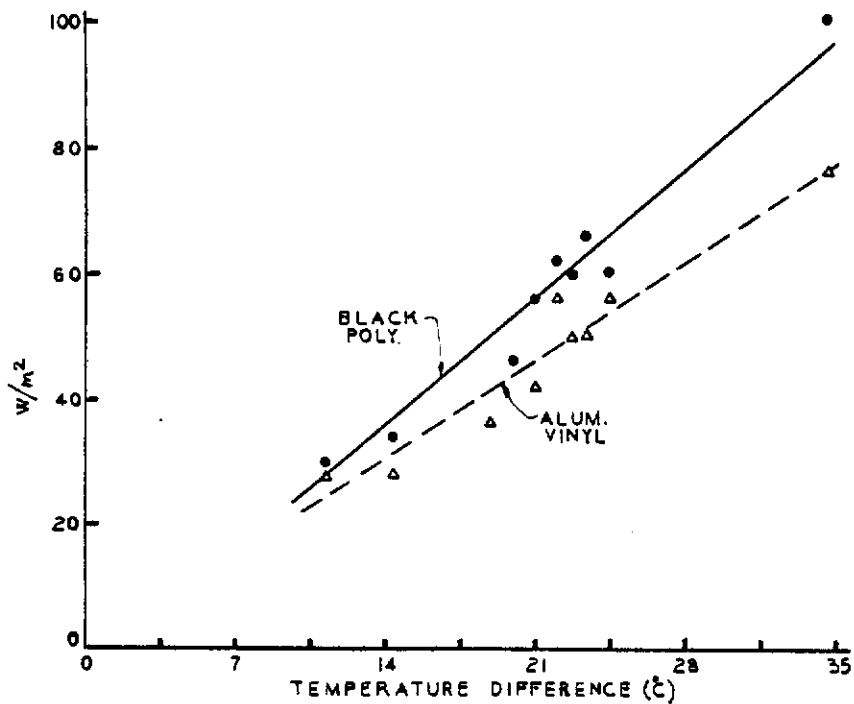

Fig. 11 Thermal Transmittance of Greenhouse, Black Poly Curtain vs Aluminized Vinyl Curtain

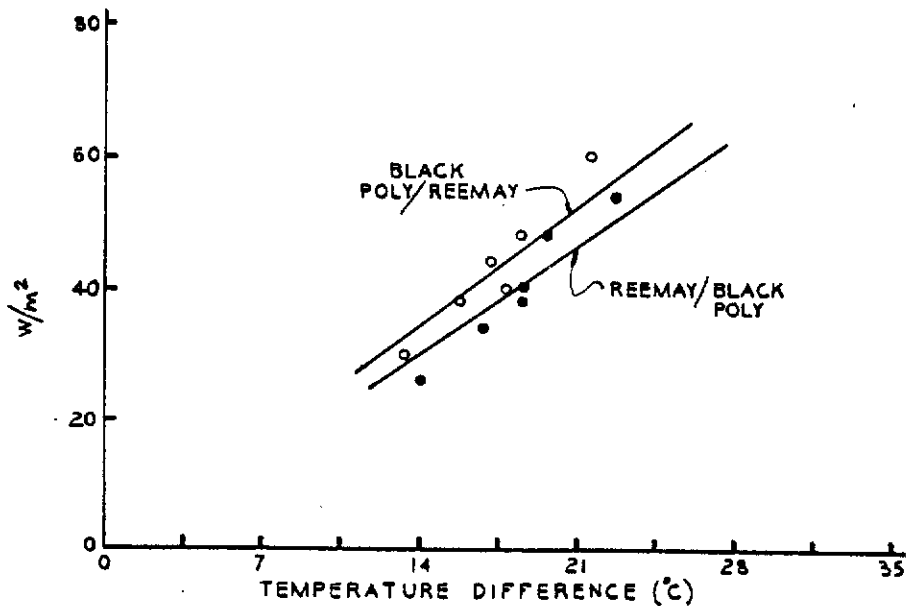

Fig. 12 Thermal Transmittance of Greenhouse, Black Poly over Reemay Curtain vs Reemay over Black Poly Curtain

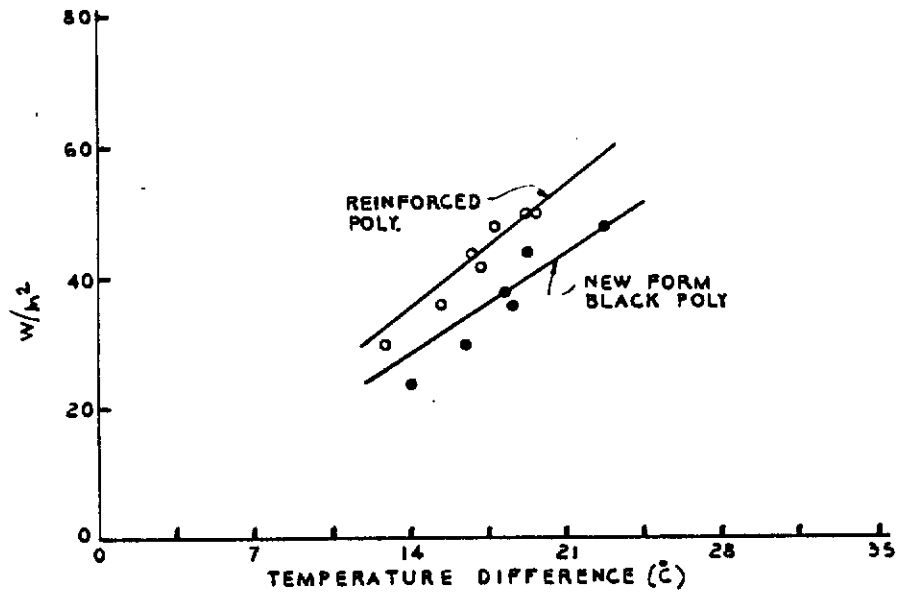

Fig. 13 Thermal Transmittance of Greenhouse, Reinforced Poly Curtain vs New Formulation Black Poly Curtain

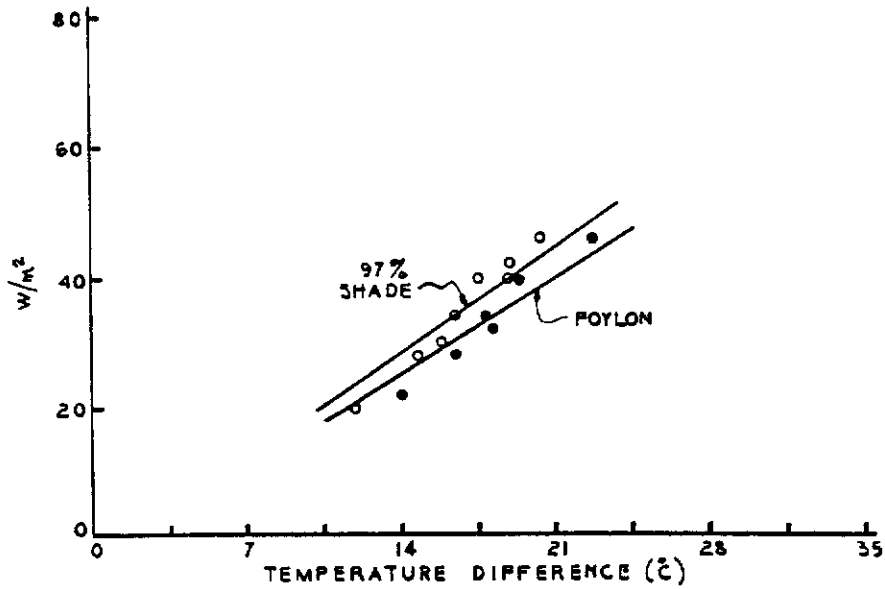

Fig. 14 Thermal Transmittance of Greenhouse, Black Poly 97% Shade Curtain vs Foylon Curtain

Figures 9-14 illustrate the results of the thermal analysis. The slope of the regression line calculated for each set of data points is the heat transfer coefficient for that particular curtain-roof combination, since the y-axis units are W/m² and the x-axis units are degrees centigrade. Table 1 shows the slope and correlation coefficient for each of the curtain materials. Figure 15 summarizes these results, showing the median value for the heat transfer coefficient surrounded by an interval of plus and minus two standard deviations. Examination of Fig. 15 reveals that when a range of possible values for the coefficient are observed, many materials perform around the 50% reduction in heat loss value (when compared with an uninsulated value of 4.5 W/m²K). Analysis of the data indicates that there is no statistically significant difference among any of the nine materials on the right of Fig 15. Differences in performance due to changes in closure of the curtain from night to night and weather have more influence on overall performance than curtain properties.

=====

TABLE 1 CURTAIN HEAT TRANSFER VALUES

Material Tested	Slope of Regression Equation	Correlation Coefficient
Reemay	3.59 W/m ² K	r ² = 0.97
Double Knit	3.53	0.99
Black Poly	2.70	0.92
Reinforced Poly	2.59	0.98
Poly/Reemay	2.49	0.97
Reverse	2.38	0.97
Reemay/Poly	2.21	0.96
Aluminized Vinyl	2.18	0.93
Polypropylene Shade	2.16	0.95
New Form. Bl. Poly	2.10	0.97
Foylon	1.93	0.95

=====

This means that a number of materials could be used with satisfactory results thermally. Perhaps then other factors should be considered to determine the proper material to use.

Eleven different materials were tested, and they can be divided into three groups according to drainage characteristics. One group tested, including Foylon, Reemay, a double knit fabric, and polypropylene shade mesh, was porous. The Foylon (Fig. 14) material was composed of a woven polyester cloth material laminated with aluminum. It was quite flexible and lightweight. As a result it was easily installed and did not burden the mechanical system. When collected condensate forms a small pocket, the static pressure forces the area to drain. It was quite strong and performed extremely well thermally, since it effectively inhibits air movement.

Both the Reemay (Fig. 9) and double knit fabric drain very well and are easily handled. The double knit (Fig. 10) was slightly stronger than the spun bonded polyester Reemay curtain. These curtains are porous to air and did not totally inhibit the convective movements in the house. As a result they were relatively poor thermally. However, it is significant to note that these materials have the potential of doubling as a controllable

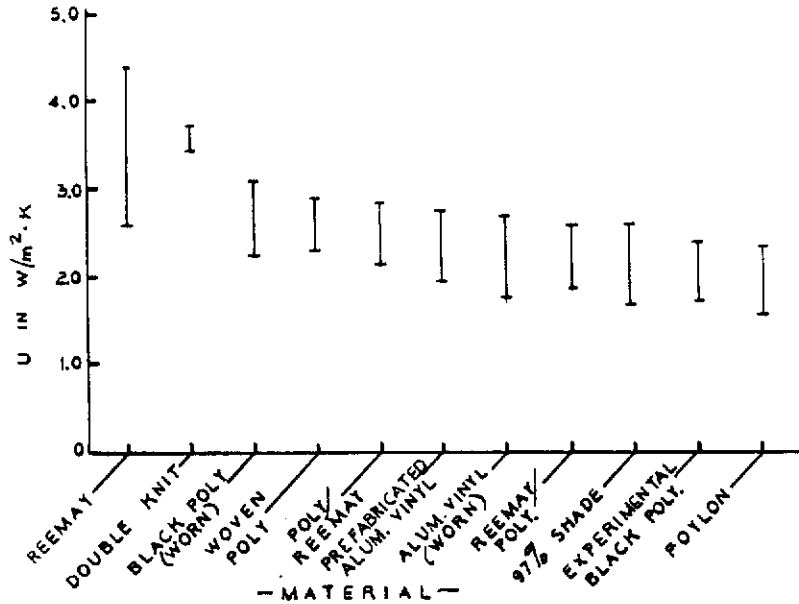

Fig. 15 Chart of Curtain Type vs Mean U Value

summer shade material instead of the whitewash usually used to reduce summer light levels.

In contrast, the polypropylene shade mesh (Fig. 14) performed well thermally, but the material was stiff and heavy. Thus these curtains were relatively difficult to handle and install and were not easily compacted when the system opened. This material did drain in a manner similar to the Foylon.

Neither the black polyethylene or the aluminized vinyl curtains (Fig. 11) was porous. The fact that these curtains did not drain contributed to their relatively rapid deterioration, since the weight of the collected water strained the material and the system. The polyethylene was lighter and easier to install, but the aluminized vinyl was stronger and performed better thermally. These curtains were evaluated after a period of use and subsequent wear. Later, some polyethylene curtains were drilled with 3 mm holes on nominal 8-cm and 15-cm spacings to drain off condensate.

Several other nonporous curtains drained because of fabrication. The reinforced woven polyethylene curtain (Fig. 13) drained where it was stitched. It performed well thermally, but was a heavy and stiff material. It compacted more easily than the polypropylene shade mesh, but not as well as some of the other materials.

A black polyethylene curtain, which was a new formulation (Fig. 13), had holes drilled in it on 15-cm centers. It drained adequately, but did contain localized pockets. The material was light (3 mil) and compacted well. It was stronger than the standard polyethylene curtains, but once damaged deteriorated rapidly.

Two curtains were composites of drilled polyethylene and Reemay (Fig. 12).

These curtains drained well, and the Reemay helped eliminate the localized dripping that accompanied the other drilled polyethylene curtains. The double material was moderately difficult to install, but it was easily moved and compacted when opened by the system. These curtains were slightly stronger than either material on its own.

The Revere curtain (Fig. 10) was an aluminized vinyl curtain with a mesh strip sewn in for draining. This mesh drain was stiffer than the material and actually inhibited drainage by destroying the natural catenary of the material, which should have brought the water to the center to drain. The curtain was extremely easy to install due to extensive prefabrication and compacted well when opened. The open mesh in the center did allow some convection through the curtain, reducing its thermal performance.

Each curtain was evaluated on a scale of 1 to 5 for its ability to drain, durability, ease of installation, and mechanical characteristics while operating. Drainage and durability were then combined into one parameter, since the drainage characteristics of a curtain directly influenced its durability. The mechanical characteristics and ease of installation were also combined, since both depended on material weight and stiffness. These ratings are presented in Table 2. It must be noted that these ratings are relative in nature and based solely on observation.

=====

TABLE 2 CURTAIN PHYSICAL RATINGS

<u>Material</u>	<u>Drainage/durability</u>	<u>Mechanical</u>
Double Knit	1	1
Foylon	1	1
Reemay	2	1
Reinforced Poly	1	3
New Form. Poly	3	2
Shade Polypropylene	1	5
Reemay/Poly	3	3
Poly/Reemay	3	3
Revere	4	2
Black Poly	5	2
Al. Vinyl	5	3

=====

To get a final rating for each curtain, the heat transfer coefficient was multiplied by 0.70 and each of the other ratings were weighed evenly and multiplied by 0.15. Then the results were totaled. The subjective weights given to each rating were based on their relative significance. These opinions were formed based on observation of the man-hours required to repair the system for a given failure. It was decided that a 30% weight was a fair value for characteristics relating to repair time. The materials were then ranked as shown in Table 3, with the lowest score indicating best performance. It is evident that Foylon scored ahead of the other materials in all characteristics. The margin that separates it from the second material is equal to the margin separating the second-placed material from the eighth-place material. However (as was stated previously) the nonthermal ratings are based on observation and are subjective in nature. It is evident that significant energy savings were obtained from all materials.

TABLE 3 FINAL CURTAIN RANKINGS

<u>Material</u>	<u>Score</u>
Foylon	1.65
New Form. Poly	2.22
Shade Polyprop.	2.41
Reemay/Poly	2.45
Reinforced Poly	2.56
Revere	2.57
Poly/Reemay	2.64
Al. Vinyl	2.73
Double Knit	2.77
Black Poly	2.94
Reemay	2.96

The importance of good sealing practices is illustrated by comparing the overall greenhouse heat loss coefficient from two examples. During the fall 1978 and spring 1979 growing seasons, the greenhouse was identically managed and equipped. A rigorous maintenance schedule was followed to alleviate the condensation problem on the nonporous curtains.

For the spring season a polyethylene convection tube was installed as an inflated gasket along the greenhouse gutter to enhance the sealing of the leading edge. A drop in the greenhouse heat transfer coefficient from 3.2 to 2.3 W/m²K (28% reduction) was attributable to this sealing practice. This translated to an increase in energy savings due to the insulation system from 38 to 50%. The curtains were identical in both seasons, only the sealing system was changed. The effects of various classes of curtains on heat loss are shown in Fig. 16

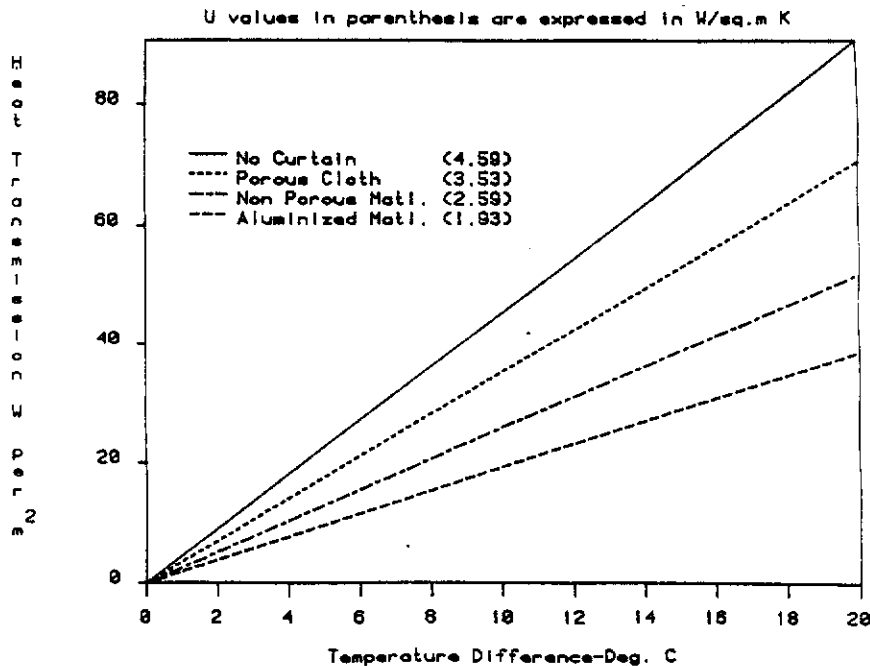

Fig. 16 Effects of Various Curtain Types on Heat Loss

Auxiliary Heating System

This section is an illustration of the methods used to determine the heat input of the oil burners used as back-up for the solar system. All the results shown here were calculated with the boilers operating in a steady-state condition. At times during the operation of the greenhouse, the boiler water temperature maintained by the boilers was changed. This was accounted for when preparing the section on overall system performance.

The fossil fuel back-up system can be divided into two systems that operated independently, although they were attached to the same boilers. One system was an overhead pipe loop (see Fig. 1) common to many hot-water greenhouse heating systems. The purpose of this unit was to maintain a set minimum greenhouse temperature in the event that the heat input from the floor proved inadequate. The second back-up system consisted of two heat exchangers located in the perimeter greenhouse return flume (see Fig. 2). The purpose of this system was to maintain a minimum storage temperature that would ensure floor heating if the collectors were unable to provide it.

To determine the heat input of either system, certain parameters had to be monitored for each. Copper-constantan thermocouples were located in the inlet and return pipes in each system. The other variable that needed to be determined for each unit was the water flow rate in the pipe loops. From this a mass flow rate was determined to be used in the equation for heat transfer:

$$q = \dot{m} c_p (T_1 - T_2)$$

which was discussed earlier.

The flow to the floor heat exchangers was monitored with two CORAD integrating flow meters. To determine the rate of flow, the system was operated for a given amount of time and the flow for this period was recorded. These measurements were made periodically over the season to ensure valid values for the heat input of the system. It was found that flow rates were constant for all times checked. The temperatures encountered throughout the overhead system were too high to use a CORAD meter similar to that used with the heat exchanger loops. As a result two low head orifice meters were used to determine the flow rate. These calibrated orifice meters were connected to a differential mercury manometer. The measured pressure drop allowed flow rate determination to be made from a calibration curve provided by the manufacturer.

Three separate tests were undertaken. First, the floor heat exchangers were manually operated and monitored to determine when steady state operation had been achieved. Then the average water temperatures over the experimental period were used to compute the heat input of the heat exchange loops, the heat gained by the floor, and the heat exchanger effectiveness. The heat exchanger effectiveness is defined as the actual rate of heat transfer divided by the theoretical maximum rate of heat transfer (Kreith and Kreider 1979). The following results were obtained:

Temperatures in the System °C

Boiler 74	South return 26	North return 31	Floor in 12	Floor out 22
--------------	--------------------	--------------------	----------------	-----------------

Mass Flow Rate South 165 kg/min	Mass Flow Rate North 146 kg/min
------------------------------------	------------------------------------

Heat Exchange

South input 560 kW	North input 440 kW	Floor gain 1000 kW
-----------------------	-----------------------	-----------------------

Heat Exchanger Effectiveness

$$\epsilon = (T_1 - T) / (T_2 - T_2)$$

where:

T_1	= inlet temperature hot side
T	= outlet temperature hot side
T_2	= outlet temperature cold side

Then $\epsilon_{\text{south}} = 0.78$ and $\epsilon_{\text{north}} = 0.70$

The same type of test was conducted with the overhead pipe loops that heat the greenhouse air. The circulators were turned on manually and monitored closely until steady-state conditions had been reached. Average values for temperature over the time period of the experiment were determined and used to calculate the heat input from both overhead loops. In this case heat exchanger effectiveness was not determined, since available formulae did not pertain to this application. The results obtained are shown below.

System Temperatures °C

Boiler 84	South return 76	North return 75
--------------	--------------------	--------------------

Mass Flow Rates	
South 260 kg/min	North 250 kg/min

Heat Inputs	
South 140 kW	North 180 kW

Part of the reason for the difference in heat inputs between the north and south loops in this case is that the north loop heats two bays on the south side of the greenhouse as it travels to and from the boilers, which are located in the southwest corner of the greenhouse.

The last set of results presented shows the heat input when both systems were operating simultaneously. The data were obtained during a period of actual greenhouse operation, as opposed to the previous experiments, which were conducted when the greenhouse was empty. These results also allow for a computation of boiler efficiency, since the boilers run at capacity when

both systems are in operation. The rate of oil consumption was assumed to be correctly stated by the manufacturer. While operating together the overhead system input 330 kW of heat energy, while 900 kW was furnished from the floor heat exchangers. The boilers were rated at 1560 kW. This indicates that the two boilers were operating at a combined efficiency of 79%. There is a 2% difference in the values obtained for the overhead system when comparing their operation alone with their operation in combination with the heat exchangers. This is within the accuracy of the orifice flow meters, so it can be assumed that there is no difference in the operation of the overhead system. The floor heat exchangers on the other hand show a drop in heat output of 11% when the overhead loops are also running. It can be assumed that the floor heat exchangers would input slightly more energy when operating alone than when operating in the combined mode. The flow rate in both systems does drop slightly when in combined operation, but this was accounted for in the analysis.

A possible explanation for the drop in performance can be found by exploring the heat exchanger design. The floor heat exchangers were designed with a fouling factor of 0.5. As a result they operated originally at twice the output required. In two years of operation the output had dropped by 20%. This means that the floor loops were operated in an overdesigned condition, as 2 years operation had not yet produced exchanger surface fouling as great as that allowed for in the design. Thus when both back-up systems were in operation, the possible heat input exceeded the boiler capacity, dropping the boiler jacket temperature and the floor loop input temperature until total heat transfer matched the boiler output.

The overhead pipe loop output, translated to 168 W/m of pipe, is within 9% of the predicted heat output of 192 W/m based on the heat transfer coefficient for steel pipe at the design temperature found in the ASHRAE (1965) guide. Since the flow meter's calibration chart was accurate to 10%, this difference is within experimental error.

SYSTEM PERFORMANCE

The system has been in operation since spring of 1978. The first season for which complete heating data were available began in September of 1978. Since that time four crop seasons have taken place. The house has been operated under three different cropping schemes: poinsettias were grown each fall season in pots placed on the floor, bedding plants have been grown directly on the floor in the spring season, and during January and February of 1979 the house was used for seed germination.

The energy balance for a greenhouse is quite complex. In a solar greenhouse where thermal mass and energy storage come into play, the problem is magnified. As a result certain simplifying assumptions and limiting experimental conditions must be made. An energy balance for this greenhouse can be written as:

$$q_b + q_o + q_h + q_s + q_{pa} + q_e + q_{st} + q_r = q_t + q_p + q_c + q_{rd} + q_g + q_v + q_i$$

where:

- q_b = boiler standby losses
- q_o = overhead system input
- q_h = floor heat exchanger input
- q_s = solar collector input
- q_{pa} = passive solar gain of greenhouse
- q_e = heat input from equipment
- q_{st} = net energy decrease of storage
- q_r = heat from plant respiration
- q_t = energy used in plant transpiration
- q_p = energy used in plant photosynthesis
- q_c = heat lost by conduction and convection
- q_{rd} = heat loss by radiation
- q_g = heat flow down into the ground
- q_v = sensible heat loss in ventilation
- q_i = heat losses due to infiltration.

Walker (1965) reported information that allows some simplification of this equation, since plant photosynthesis accounts for only 3% of the light energy in the most extreme case and this is more than an order of magnitude smaller than the greenhouse passive gain. At maximum, plant respiration is 1/10 of the energy of photosynthesis and therefore can be ignored.

Other variables can be ignored because of their small values in relation to the remaining variables. These include the equipment energy input and losses from storage to ground, which at maximum were only 3% of the energy transferred between storage and greenhouse. For this analysis convection, conduction, and radiation losses were grouped together as an overall heat loss for the structure.

To further simplify the analysis, an empirically modified degree day formula (Simpkins et al., 1978) was used to eliminate daytime transient heat flows due to ventilation, transpiration, and passive solar gain.

As a result the final simplified form of the equation can be written:

$$q_b + q_c + q_s = q_t$$

where:

q_b = total boiler input (sum of $\dot{m}_1 c_p \Delta T$ for loops)

q_c = collector input

q_s = storage energy change ($m_s c_p dT/dt$)

q_t = total energy consumption of house (0.9 x degree days x 24 x U)

All quantities can be measured directly except for U , and as a result a seasonal heat loss coefficient can be determined. This value will be presented with each seasonal heat consumption table with a description of the curtain system. Variations in this heat loss coefficient will be observed. These variations are mainly due to changes in curtain materials and sealing techniques from season to season. For this reason these values are to be used only to understand changes in energy used and not as values that should be referenced for design considerations. A design would have to be based on the U value for the curtain insulation system being used and the greenhouse in which it was installed.

This project was undertaken with the cooperation of the owners of Kube Pak Garden Plants, Inc. It was not expected that any modification of their cropping schedules would be made for experimental purposes. As a result a precisely instrumented check greenhouse was not always available at the same time as the solar section was in operation. Changes in management of the solar section were decided by the owners. Wherever practical, results for the operation of the solar house were compared with a neighboring greenhouse operating under similar conditions. The solar house was subject to different management practices during its period of operation as information increased and the grower became familiar with its operating characteristics. It should be noted that one of the most significant findings of the evaluation portion of this project has been the significance of the improvement in total system performance and the fossil fuel savings that can be achieved by optimizing management practices. For the reader's understanding of each cropping season a discussion of management practices that influenced performance is provided.

The first season of operation, fall 1978, is presented in Tables 4 and 5. Poinsettias were grown on the floor at a greenhouse temperature of 16°C. A neighboring section containing elapsed time indicators on the boilers was held at a slightly higher temperature of 18°C. Weekly energy consumptions for both sections are presented in Table 4. A U for the check greenhouse was determined to be 5.1 W/m² K. The solar section had a seasonal U of 3.2 W/m² K. This relatively high value can be attributed to poor sealing of the curtains upon closing at night. Curtains that were tested are listed next to the U value.

Table 5 presents the energy savings attributable to the solar system over the fall 1978 season. Using the heat transfer coefficient for the control section, a total energy consumption for the section based on its area and degree days was determined. This was then compared with the energy used by the section. A reduction in energy load of 38% due to insulation was recorded (Table 5). Of the remaining energy, the solar collectors provided 47%. Thus the total energy consumption from fossil fuel was reduced by 67% for the structure and all systems compared with the check section.

TABLE 4

PERFORMANCE DURING FALL 1978 POINSETTIA CROP

S O L A R S E C T I O N				C H E C K
Week	Collector GJ	Boiler GJ	Total GJ	Boiler GJ
Oct 5-11	77	36	113	190
12-18	41	38	79	194
19-25	83	15	98	206
26- 1	61	21	82	243
Nov 2- 8	37	19	56	230
9-15	37	24	61	196
16-22	23	70	93	252
23-29	12	126	138	278
30- 6	30	97	127	218
	401	446	847	2009

U = 3.2 W/m² K

50% Black Poly

U = 5.1 W/m² K

50% Aluminized Vinyl loose seal

TABLE 5

NINE WEEK ENERGY TOTALS FOR FALL 1978 SEASON

Percentages based on:	Energy GJ	Percentages check solar	
Energy required, uninsulated check	1354	100	-
Total energy used in solar section	846	62	100
Energy from collectors	401	-	47
Energy from boilers	445	33	53
Energy saved by insulation	508	38	-

During January and February of 1979, the greenhouse was used for seed germination. Although the house was not designed for this purpose, germination was accomplished, even though the weather during the period was particularly severe. This period is not illustrated in detail, since it was atypical and required virtually 100% fossil fuel input to maintain temperature. However, the performance of the curtain insulation system at this time succeeded in maintaining a greenhouse temperature above 16°C and a soil temperature above 18°C, even though the outside temperature dropped to -28°C. This was made possible by the installation of sealing gaskets, which were described earlier. Without the curtain system, the undersized overhead pipe loops and covered floor system could not have maintained this temperature difference.

For the 1979 spring bedding crop season (Tables 6 and 7), the management practices inhibited the optimal use of the solar aspects of the system. It was anticipated by management that the free operation of the solar collectors would overheat the soil in the later spring months. (Note that management of the system was substantially improved in the second year.) As a result, a thermostat limiting the upper temperature of the storage system was installed that severely inhibited collector operation, since the storage temperature was abnormally high to begin with after the germination period of operation. Four weeks of operation are analyzed, beginning when the germination period ended on February 21 and terminating when the solar collectors were turned off on March 19. During this time period, the curtain system performed particularly well, for it was well maintained and an air inflated gasket was added where the closing curtain met the gutter. A final U for a check greenhouse is presented, but since it was in operation during a different time period, weekly totals are not comparable and are not presented.

=====

TABLE 6

PERFORMANCE DURING SPRING 1979 BEDDING PLANT CROP

S O L A R S E C T I O N				C H E C K
Week	Collector GJ	Boiler GJ	Total GJ	Boiler GJ
Feb 21-25	4	91	95	785
26- 4	15	110	125	
Mar 5-11	19	107	126	U = 4.8 W/m ² K
<u>12-19</u>	<u>4</u>	<u>172</u>	<u>176</u>	
	42	480	522	

U =2.3 W/m² K 50% Black Poly.
50% Aluminized Vinyl, gasket seal

=====

TABLE 7

FOUR-WEEK ENERGY TOTALS FOR SPRING 1979 SEASON

Percentages based on:	Energy GJ	Percentages	
		check	solar
Energy required, uninsulated check	1047	100	-
Total energy used in solar section	522	50	100
Energy from collectors	42	-	8
Energy from boilers	480	46	92
Energy saved by insulation	525	50	-

=====

Table 7 shows that, despite a low contribution from the solar collectors due to their restricted operation, the fossil fuel consumption of the greenhouse was reduced by 54%. This is primarily due to the outstanding performance from the curtain insulation system, accounting for a 50% reduction on its own.

During the next season of operation (fall 1979), rising fuel prices and increasing confidence and understanding of the management options in the system contributed to a change in management practices in the solar section. Making use of the warm floor, the greenhouse air temperature was lowered gradually throughout the season.

As a result the fossil fuel energy required was reduced by 74%. This occurred despite a higher U (due to a large percentage of porous cloth curtains being tested and removal of gaskets) when compared with the previous year and a smaller contribution to the energy budget from the solar collectors due to unfavorable sun conditions relative to the preceding fall.

Tables 8 and 9 present the results of this management scheme. The month of September was run 100% solar. No check section being heated was available for direct measurement, so a U used for calculating the uninsulated energy required was taken to be $4.5 \text{ W/m}^2 \text{ K}$, a value computed for the solar section without the curtains in operation. The warm floor was credited with a reduction in fuel consumption, because it allowed the greenhouse air temperature to be reduced. Depending upon management practices, this savings can be very substantial. Clearly more horticultural evaluation is required to determine the maximum allowable air temperature reduction for various crops when floor heating systems are used.

TABLE 8

PERFORMANCE DURING FALL 1979 POINSETTIA CROP

Week	Circulators	Floor Loops	Collectors	Total
	GJ	GJ	GJ	GJ
Sept 20-26	0	0	35	35
27- 3	0	0	32	32
Oct 4-10	6	14	31	51
11-17	34	22	22	78
18-24	0	0	53	53
25-31	52	11	39	102
Nov 1- 7	33	0	29	62
8-14	4	45	4	53
15-21	14	19	17	50
22-28	0	3	31	34
29- 5	49	81	30	160
Dec 6-12	4	45	26	75
13-21	40	113	6	159
	236	357	355	948

TABLE 9

SEASONAL ENERGY TOTALS FOR FALL 1979

<u>House used as basis for percentages</u>	Energy GJ	Percentages		
		A	B	C
A Energy required if uninsulated, no floor heat	2286	100	-	-
B Energy required if uninsulated, warm floor	1561	68	100	-
C Energy used in insulated house with warm floor	948	42	61	100
Energy from collectors	355	-	-	37
Energy from boilers	593	26	38	63
Energy saved by insulation	613	-	39	-
Energy saved by floor heat	725	32	-	-

U = 3.4 W/m²K 40% Reemay, 25% Black Poly, 20% Aluminized Vinyl, 5% Shade, 5% Reemay/Poly, 5% Reinforced Poly, loose seal

Tables 10 and 11 contain results from the spring 1980 bedding plant crop. The cultural practices made optimum use of the warm floor and the solar features of the system. The U of the house was improved over the fall season by once again installing gaskets to provide a seal and replacing most of the porous fabric curtains. The U for this season was slightly higher than spring 1979 due to the use of some porous materials and a smaller percentage of aluminized materials. However, total energy saved was also increased due to cultural practices and better use of the solar collectors. In Table 10, as with the other comparable tables, unused solar contributions were not credited to the collectors. This is dramatically illustrated by the number referenced on Table 10. This is the actual solar collection compared to the amount used for heating the week of March 18-24 (the rest contributed to a rise in the storage temperature). A combined reduction in the energy consumption of the structure of 59% was recorded due to insulation and management changes. Of the remaining energy, 24% was contributed by the solar collectors. This combined with the other savings to result in a 69% reduction in the amount of fossil fuel consumed.

TABLE 10

PERFORMANCE DURING SPRING 1980 BEDDING PLANT CROP

Week	Circulator GJ	Floor Loops GJ	Collectors GJ	Total GJ
Feb 12-18	94	98	38	230
19-25	15	92	24	131
26- 3	57	108	19	184
Mar 4-10	12	49	36	96
11-17	18	23	37	78
18-24	15	7	16 *	38
25-31	14	51	34	99
Apr 1- 7	62	27	35	124
	286	455	239	980

U = 2.9 W/m² K: 45% Shade Polypropylene, 20% Aluminized Vinyl, 5% each of Foylon, New Form. Poly, Woven Poly, Reemay/Poly, Poly/Reemay, Double Knit, Black Poly, all with gaskets.

* 171 GJ collected.

TABLE 11

SIX-WEEK ENERGY TOTALS FOR SPRING 1980

	Energy GJ	Percentages		
		A	B	C
<u>House used as basis for percentages</u>				
A Energy required (uninsulated, no floor heat)	2382	100	-	-
B Energy required (uninsulated, warm floor)	1521	64	100	-
C Energy used	980	41	64	100
Energy from collectors	239	-	-	24
Energy from boilers	741	31	49	86
Energy saved by insulation	541	-	36	-
Energy saved by floor heat	861	36	-	-

Figures 17 through 22 show how soil temperatures in the greenhouse relate to the air and water temperatures. Figures 17 and 18 show the results for experiments on 10-cm pots. One pot was raised off the floor on insulation, while the other was placed directly on the floor. Air temperature immediately around the pots had more influence on soil temperature than the floor temperature. Figure, 19 for a 25-cm pot, shows similar results, but a time lag is evident due to the thermal mass of the soil system. It is interesting to note that day soil temperatures actually exceed water temperature in all cases due to passive solar gain. These data suggest that the soil warming benefits of a warm floor cannot be fully realized with potted plants until the plant canopy is fully developed to trap warm air around the pots. Figure 20 shows temperature profiles while germinating seed in flats placed directly on the floor. Floor water temperatures were elevated during this time to enhance germination.

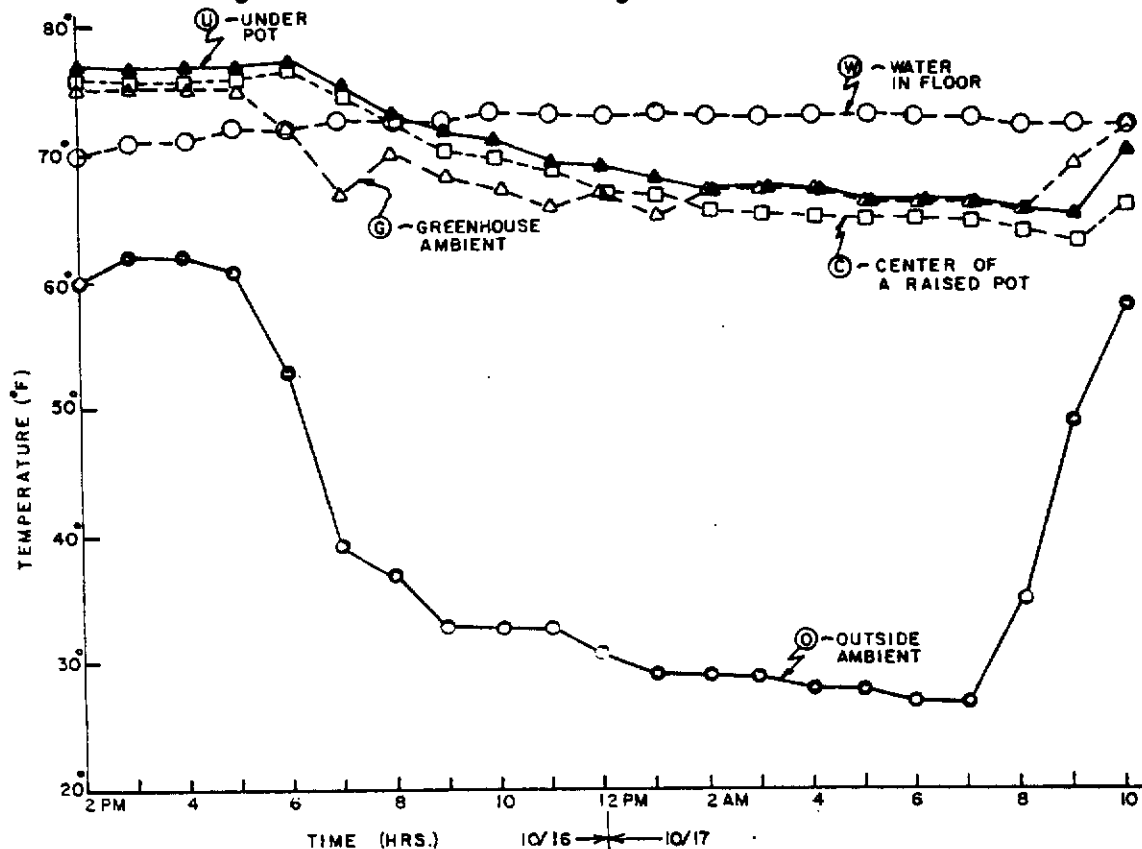

Fig. 17 Temperatures for 10 cm Potted Poinsettia in Raised Pots

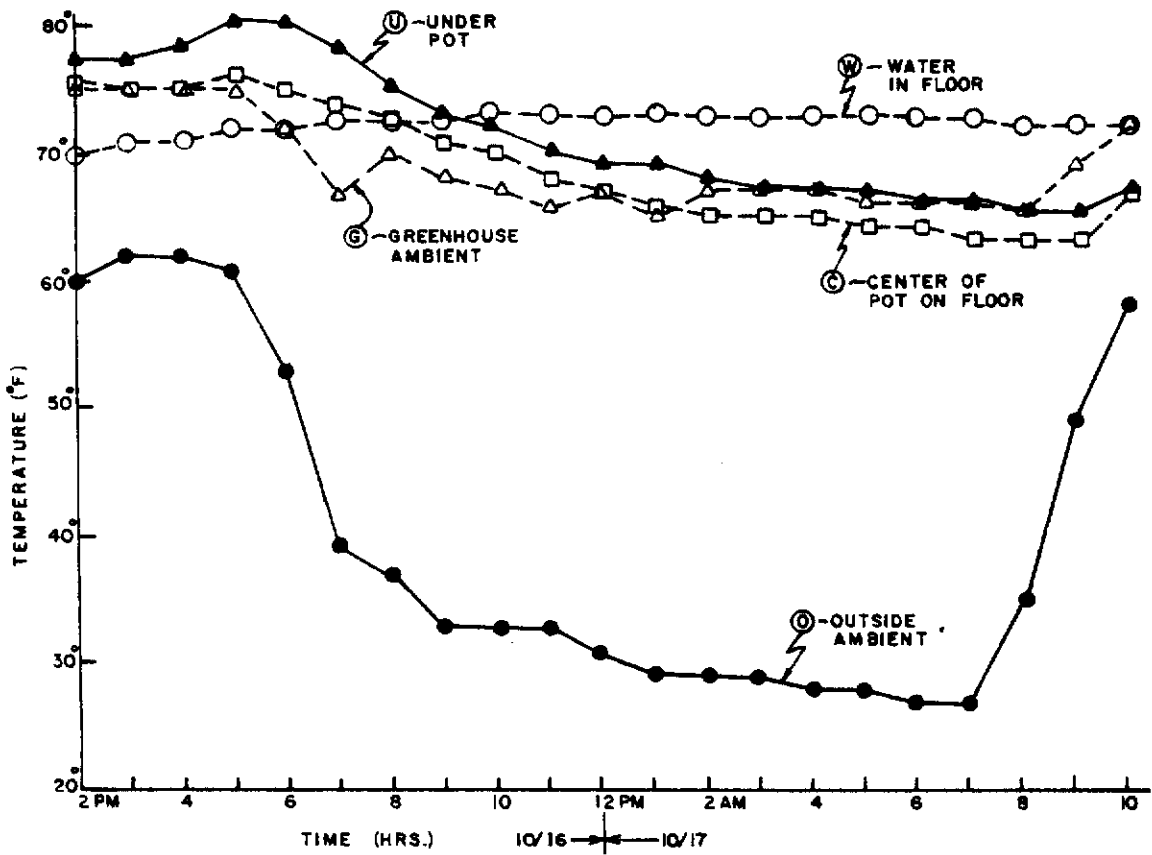

Fig. 18 Temperatures for 10 cm Potted Poinsettia in Pots on the Floor

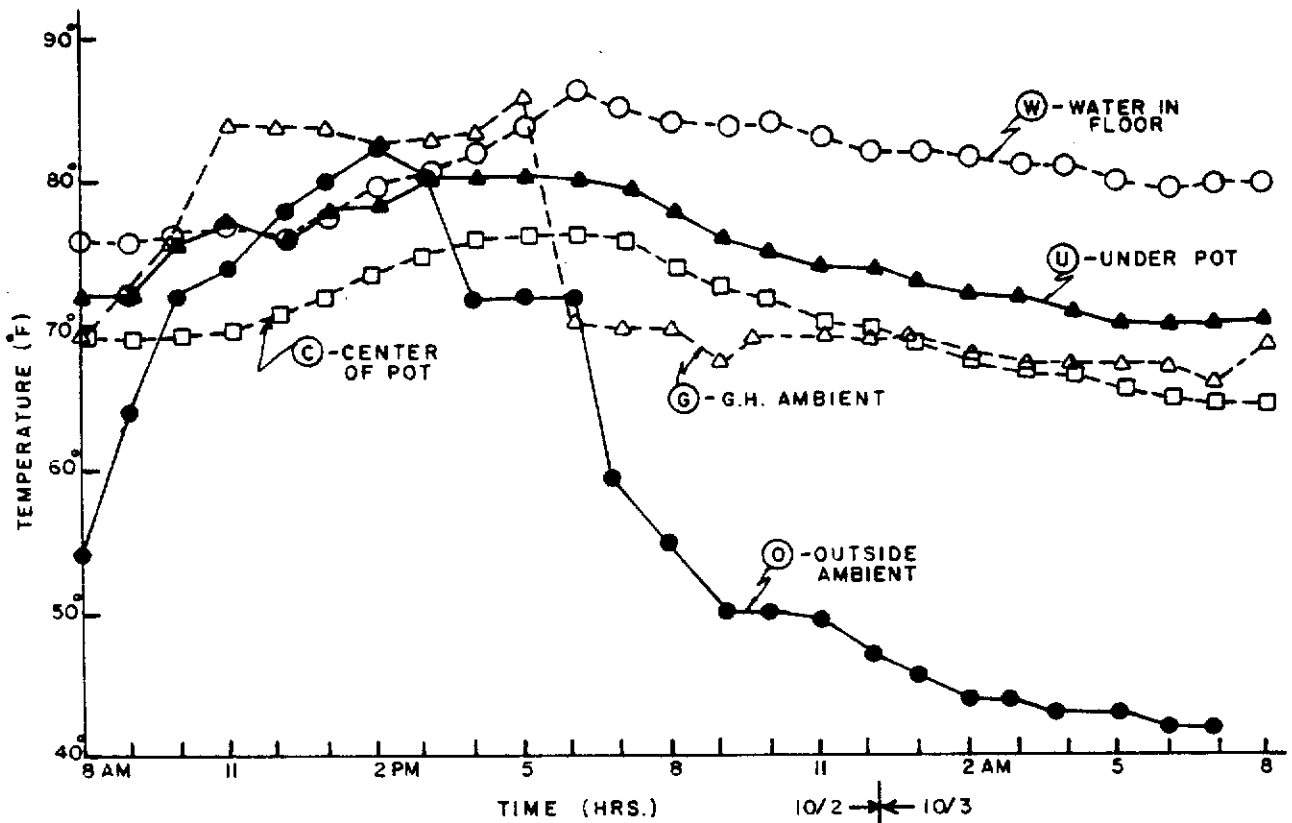

Fig. 19 Temperatures for 25 cm Potted Poinsettia

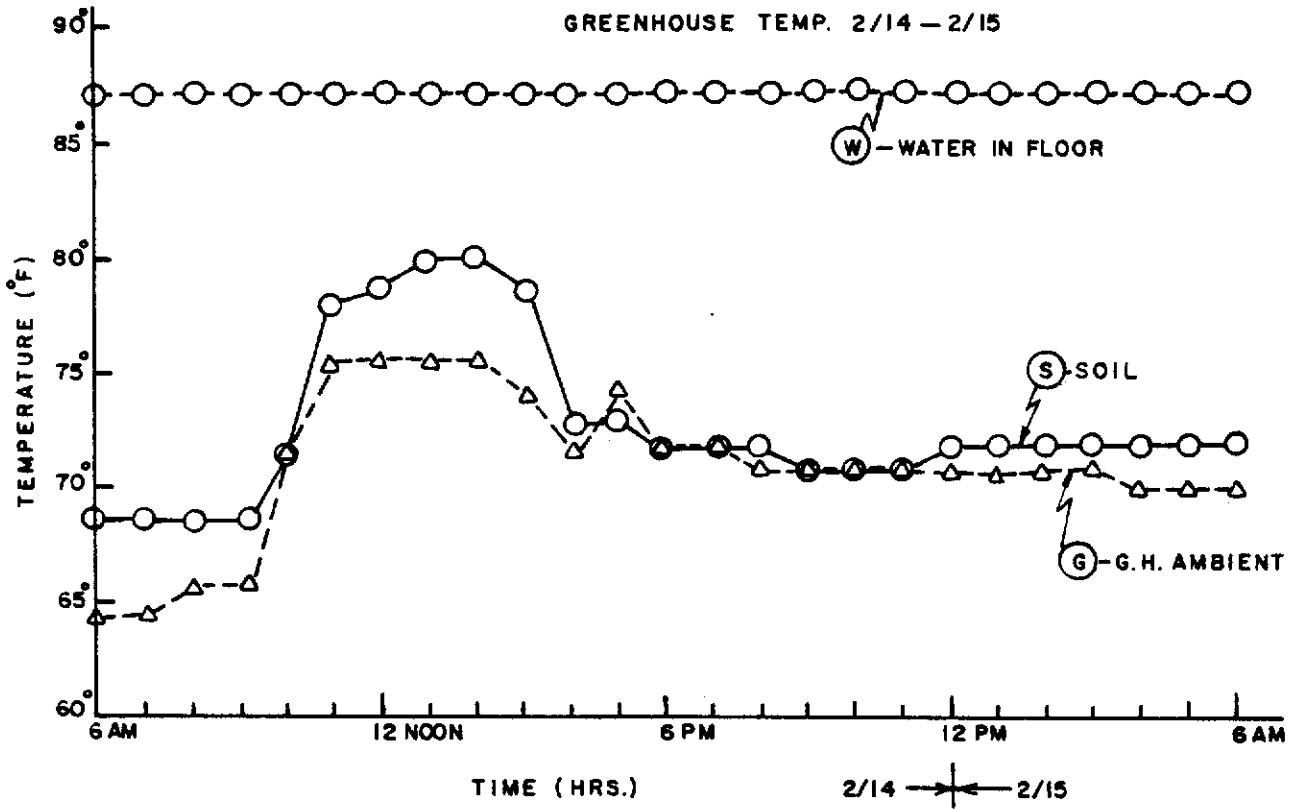

Fig. 20 Temperatures while Germinating Seed in Floor Flats

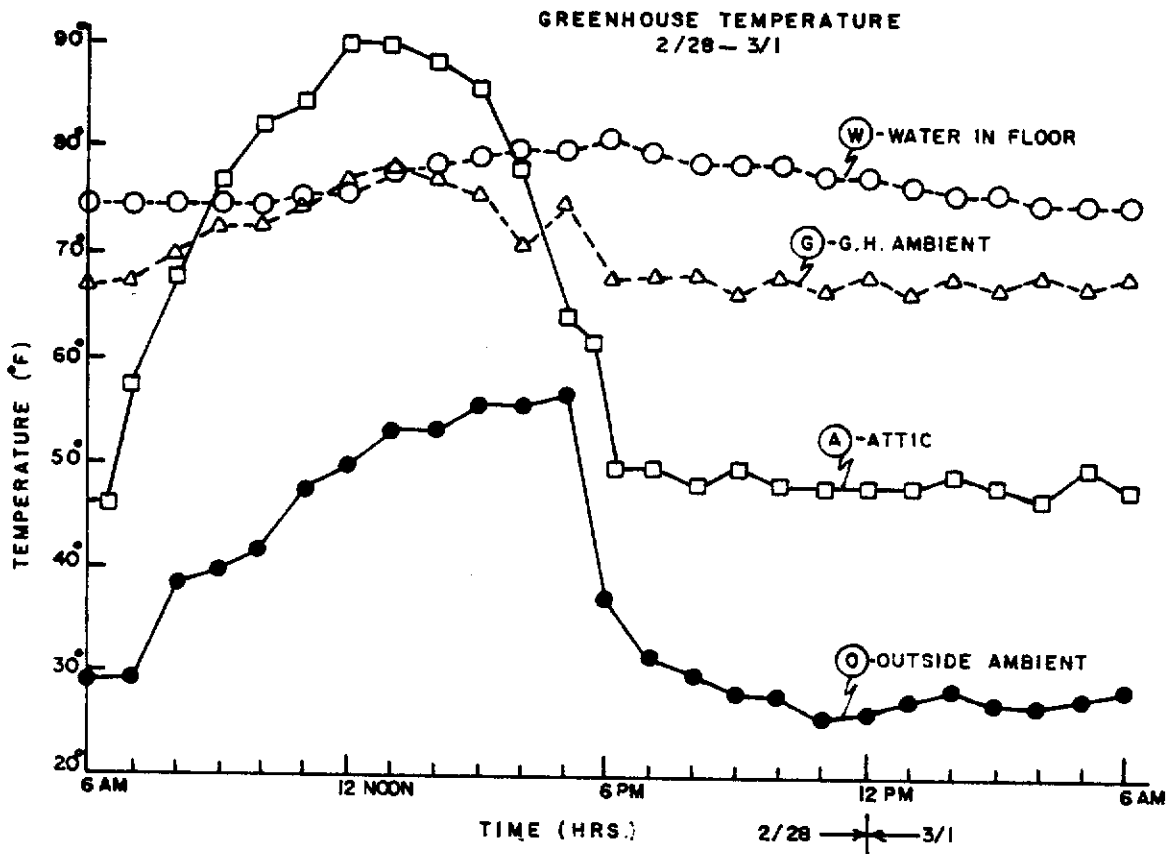

Fig. 21 Temperatures with Spring Bedding Plants Feb. 28/Mar. 1

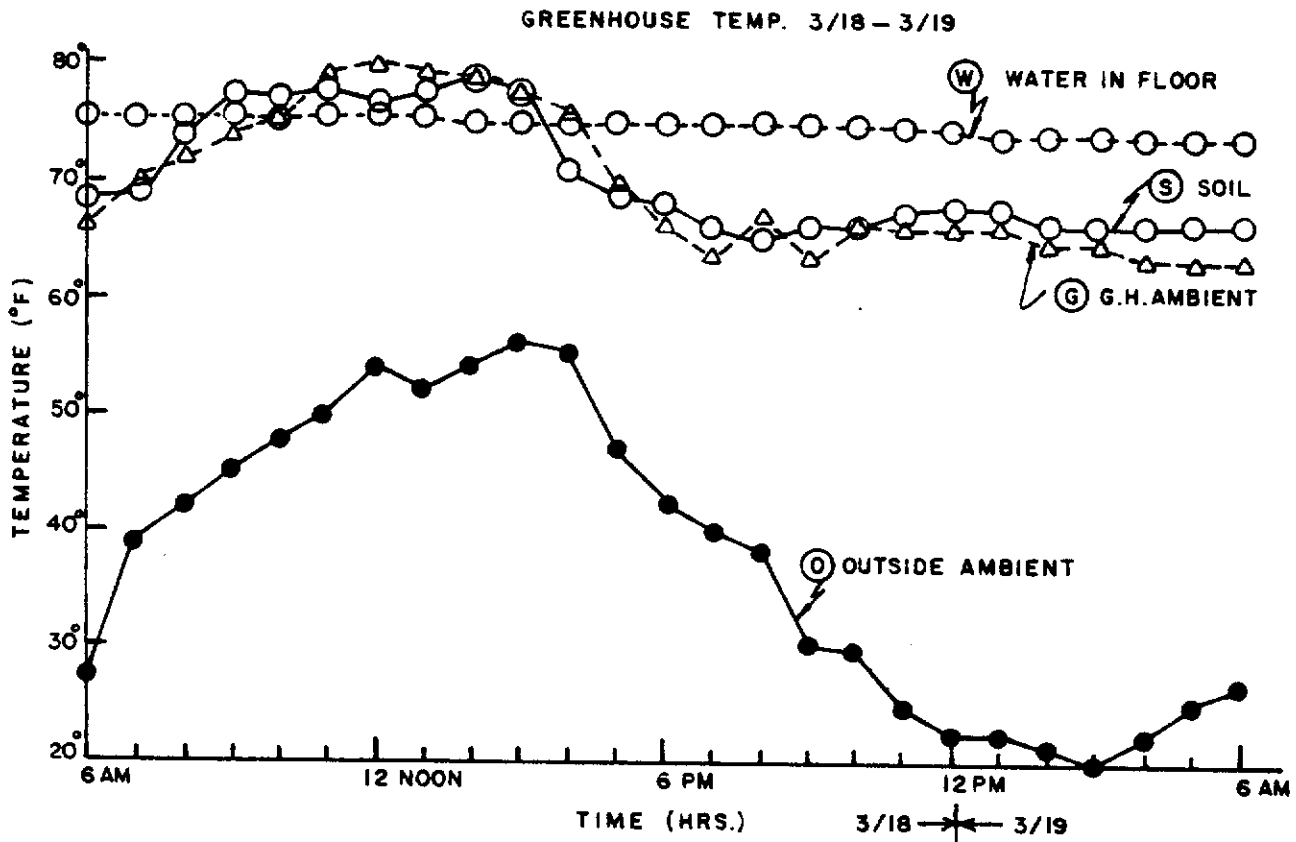

Fig. 22 Temperatures with Spring Bedding Plants Mar. 18/19

A more marked influence on the soil temperature of bedding flats can be noticed in Figs. 21 and 22. This is attributable to the more equal proportion of the flat which is exposed to the warm floor and the surrounding air. The thermal coupling varies with different types of flats. The flats evaluated here contain the soil in raised plastic trays. Manning (1980) showed a stronger coupling with flats that do not have these trays.

In order to determine the performance of the total system if operated under the best known management program, it is necessary to compute energy balances with the parameters of the system being considered and actual environmental data. This was done using parameters from the components evaluated in this program and actual weather data for fall 1979 and spring 1980. Weekly totals of solar energy collected and total energy required for a conventional house and for the Rutgers solar system for the fall 1979 and spring 1980 heating seasons are shown in Figs. 23 and 24. Note that for 5 weeks in the fall the collectors will provide more energy than the solar system requires. Also, these charts show the combined effects of curtain insulation and floor heating throughout the heating season. Note that the savings due to floor heating are more important later on in the fall, as the warm floor enabled the thermostat to be set back increasing amounts during the season, as shown in Table 12.

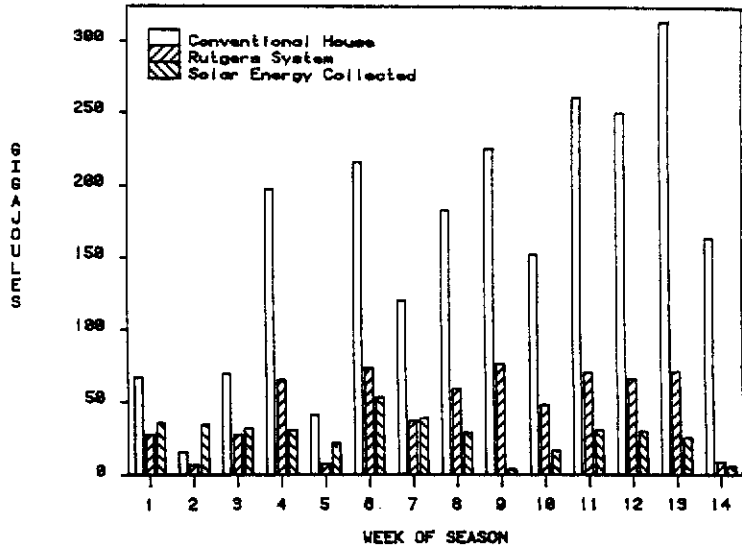

Fig. 23 Weekly Energy Totals for Fall 1979

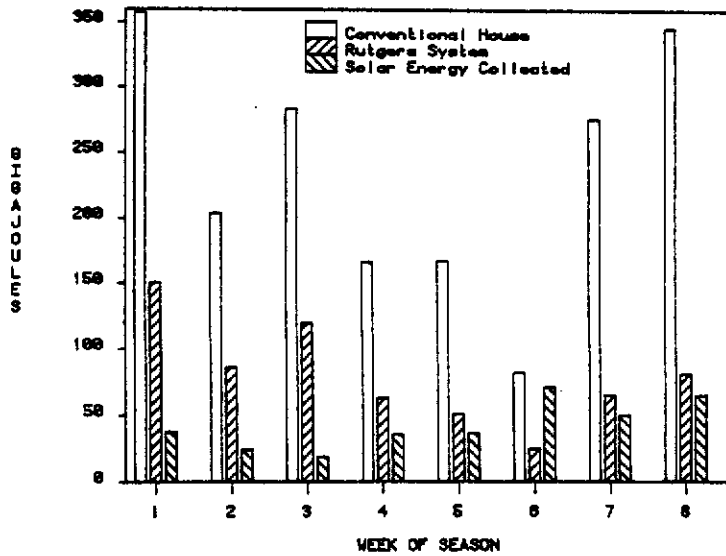

Fig. 24 Weekly Energy Totals for Spring 1980

TABLE 12
CALCULATED ENERGY CONSUMPTION OF VARIOUS STRUCTURES
BASED ON FALL 1979 DATA

Week	Temp. with Warm Floor °C	Uninsulated		Insulated	
		U=4.5 Normal* GJ	U=4.5 Warm Floor GJ	U=1.9 Normal GJ	U=1.9 Warm Floor GJ
1	18	67	67	28	28
2	18	16	16	7	7
3	18	69	69	28	28
4	16	198	158	82	65
5	16	41	19	17	8
6	16	217	176	90	73
7	16	121	89	50	37
8	16	184	143	76	59
9	16	226	185	93	76
10	16	153	115	63	48
11	13	262	171	108	70
12	13	251	159	104	66
13	10	315	172	130	71
14	10	165	22	68	9
TOTAL		2285	1561	944	645

*Temperatures with normal floor were maintained at 18°C all season.

A summary of the findings of this research is shown in Tables 12 and 13. Each column in Table 12 represents a different condition for analysis with the fall 1979 weather data. Different types of plastic houses, with and without warm floor heating and insulation systems, have their energy consumption tabulated for the fall season. The insulation system would be entirely composed of the best curtain material with good sealing techniques. The warm floor heated houses follow the temperature schedule shown, which was used for the fall 1979 poinsettia crop. The other houses would maintain 18°C. Table 13 and Fig. 25 show the resulting reductions in the fossil fuel consumption with each step until, at the bottom, the solar contribution for the fall season was subtracted from the fuel required for the insulated house with a warm floor. A reduction in the seasonal energy budget required from fossil fuel could be as much as 87%, when compared with a conventionally heated, uninsulated, double-covered polyethylene greenhouse.

TABLE 13
SEASONAL ENERGY TOTALS COMPARING VARIOUS STRUCTURES

Uninsulated poly house	= 2285	100%
Uninsulated poly house, warm floor	= 1561	68%
Insulated poly house	= 944	41%
Insulated poly house, warm floor	= 645	28%
Subtracting solar contribution	= 304	13%

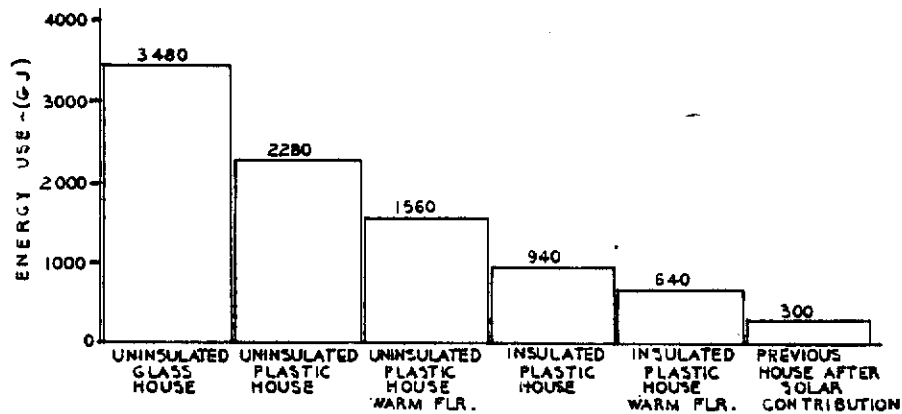

Fig. 25 Calculated Energy Required from Fossil Fuel for Fall 1979 for Several Systems

Similar results could be tabulated for the spring season. Fossil fuel requirements would be higher for the spring season, because the solar collectors contributed less to the energy budget. During the break between the seasons, the house was kept from freezing by solar energy for the most part (the circulator loop operated for 6 hours total from December 27 through February 15). Thus the fossil fuel requirement for the slack between seasons was reduced radically.

These values show that attention should be given to the type of crop grown. A management scheme that lowers the air temperature when possible results in significant energy savings (37% and 32% for the spring and fall seasons in this case).

It must be emphasized that that these savings are due to the entire system and the way the components interact. The solar collectors would not function efficiently without a method of using low temperatures to heat the greenhouse. The large heat exchange area of the floor allows the collectors to operate at lower temperatures. In contrast, too high a storage temperature might overheat the soil, so the two systems are well matched. Finally, maximal conservation is an important part of any heating system. The curtain insulation system is necessary for conservation, since even the very large floor area would not be adequate to meet the large heat demands of an uninsulated house at a low storage temperature. The warm floor is also a conservation measure, since it allows a lowering of the air temperature, the driving force for heat transfer to the outside. The system described in this paper works because it is composed of interacting components designed to enhance each other's operation in this application.

SYSTEM ECONOMICS

It is clear that the fuel saved is closely tied to system management and therefore an economic analysis based upon a specific operational mode would not necessarily apply to any general case. Emphasis in this program has been on the development of a workable system, on minimization of the fossil fuel requirement and on understanding how the various system components work on an individual basis and how they interact to provide total system performance. However, economics is obviously very important and a system must be reasonably cost-effective if it is to be adopted widely by the industry.

Total system construction costs of \$143,600 were reported by Mears et al., (1978) and in the Phase IV final report. These costs included the center concrete walks, concrete peninsula walks, and the baseboards for the outside edges of the greenhouse, which would have been required in conventional construction. Also, there was no credit taken for the portion of the conventional overhead heating system that was not constructed. In this case it was estimated that about \$9,000 worth of overhead heating pipe was saved. Therefore, if the cost of \$143,600 is taken as the add on cost for solar energy and energy conservation measures, it is a conservatively high estimate.

To determine the value of annual energy savings, a conservative estimate would be to take the actual fuel saved in the fall 1979 and spring 1980 growing seasons reported in Tables 9 and 11. At \$10 per GJ of energy, a representative price during the 1979-80 heating season, the fuel saving is \$33,340, or 23% of the total system cost. This does not include any of the savings due to maintaining the greenhouse above freezing for 2.5 months between crops with virtually no fossil fuel input. Based on the data in Table 13 it can be shown that if all the insulating curtains were of the best material tested, there would have been an added savings of 17% for a total savings of 27% of the initial investment each year.

FURTHER COMMERCIAL APPLICATIONS

There have been a number of commercial applications of the system described in this report. In some cases all the elements were similar to those described. In several commercial orchid houses and several high school vocational greenhouses where growing was to be on benches, the porous concrete cap was left out. In one residential application, paving bricks were substituted for the porous concrete. Plans for the floor system and for the solar collectors have been selectively distributed to a number of interested persons. In support of these plans preliminary bills of materials and construction instructions have been developed. These instructions are reproduced in following sections.

A proposal was prepared and submitted for support for the development of two publications on the solar heating of commercial greenhouses. The first was to be a state-of-the-art document reviewing the progress that has been made in research and commercial demonstration programs. The second was to be an extension-type publication describing the methods to design, construct and operate a commercial greenhouse solar heating system. The proposal was not supported. Peer reviewers commented that enough information has already been developed on the subject.

TECHNICAL SPIN-OFF

There has been a substantial commercial application of several of the components and concepts developed under the research program and commercial demonstration of the solar system. The warm floor heating system demonstrated in a full-scale, commercial system at Kube-Pak has aroused intense interest in the horticultural industry. As a result of this demonstration and several other commercial applications of floor heating systems developed at Rutgers, there have been commercial installations totalling at least 100 hectares throughout the United States. It should be noted that, in general, growers are first attracted to this system for horticultural reasons, primarily, independent control of the temperature of the root environment. The importance of the floor heating system as an energy conservation tool develops as optimal management of temperature regimes for various crops is learned by the grower.

A number of techniques for heating greenhouse floors have been developed. The most common in commercial practice consists of 2-cm polyethylene pipes embedded on 0.3-m spacings in a porous concrete floor. Warm water heated to about 35°C is circulated through the pipes. The energy for these systems is usually provided by fossil fuel boilers. However, such systems should be fairly easy to retrofit for solar energy, especially as the required operating temperature is fairly low.

There has been an ongoing research program directed toward the use of the flooded floor heat exchange system for the utilization of reject heat from electric power generating stations or other industrial sources. Results obtained at Kube Pak indicate that, with a flooded floor heating system and an effective curtain insulation system, it should be possible to carry virtually all of the heating requirement of a greenhouse as long as warm water is available at temperatures of 30°C or higher. Utilizing the data obtained in the solar research program, a 1.1-hectare greenhouse to be heated with reject heat from an electric generating station has been designed.

An intense interest in movable blanket insulation systems is now developing. Although the cost effectiveness of these systems has been reported for some time, commercial applications have not been widespread. This is probably due in large part to grower reluctance to install mechanical systems that appear to be complicated compared with conventional environmental control systems. The Kube Pak demonstration project has enabled the industry to observe a full scale system in operation over two full heating seasons. Significant mechanical improvements in the system have been achieved. Side-by-side evaluations of the performance of a number of materials have been conducted, with each test section being a full-size commercial module. A number of materials now being used commercially were evaluated during the course of the project and one of the insulation materials developed under the project is being used commercially on a large scale.

CONCLUSIONS

1. The system performed up to expectations throughout the 2 year testing period. Original projections anticipated a 25% contribution from solar to the reduced heat load (based on actual size). The collector field actually contributed more than 25% during most of the system operation.

2. Fuel consumption has been drastically reduced by the system. Fuel oil consumed was reduced by 45% the first year, 73% for the fall 1979 season, and 69% for the spring 1980 season.

3. An acceptable curtain material should meet the following criteria: Reduce the U value by 50%, drain, and be light, flexible, and strong.

4. The solar collectors can be constructed in large units and still operate effectively.

5. The system has been shown to operate effectively on a large scale. There are significant economies of scale to be realized when constructing on a large scale and the system components operate more efficiently in a large greenhouse.

6. Although there has been no rigorous economic analysis, it has been demonstrated that in the most recent heating season the total system saved 23% of the construction costs. If properly managed the system can be cost-effective.

FUTURE CONSIDERATIONS

In this section problems encountered during the operation of the system are summarized and possible solutions are suggested.

The solar collectors performed as well as any similar collectors constructed to date. Some problems due to plastic degradation were encountered. Collectors could be covered once every 2 years if they are allowed to remain covered through only one summer. Some problems with the collector framing were encountered, but they were corrected. One recurrent problem was the loosening of a connection on the main distribution pipe. This connection was made to be disassembled when covering the greenhouse, but this proved unnecessary. In the future all main connections should be permanent.

The center distribution flume in the greenhouse was not constructed to the proper design depth. This resulted in leakage when the auxiliary floor loops operated, which hampered proper flow distribution. A better floor water distribution system, which would channel water directly to the bay inlets, needs to be considered.

Many man-hours were spent on the curtain insulation system. These hours would be drastically reduced by the selection of the proper curtain material. Also in this system edge-sealing was a problem, since the curtains did not go to the edges of the greenhouse or meet each other in the middle. As a result extra time was spent installing additional seals around the edges. These seals could be eliminated by using curtain track systems mounted on the greenhouse walls.

Microprocessor control of this system is an area that needs to be researched in the future. This would allow closer monitoring and exacting control of the system with a minimum of user input.

REFERENCES

- Baird, C.D. and D.R. Mears. 1976. Performance of a greenhouse solar heating system. Proceedings of the Solar Energy-Fuel and Food Workshop, Environmental Research Laboratory. The University of Arizona, Tucson, Arizona.
- Cipolletti, J.P. 1978. Residential application of the Rutgers solar heating system for greenhouses. Unpublished research paper.
- Cipolletti, J.P. 1980. Performance of the Kube Pak greenhouse solar heating demonstration project. Master's thesis.
- Gebhart, B. 1961. Heat Transfer. McGraw-Hill Book Co. New York, New York.
- Hill, J.R. and J. Kusuda. 1974. Methods of testing for rating solar collectors based on thermal performance. NBSIR 74-635. National Science Foundation. Washington, D.C.
- Kendall, P.W., D.R. Mears, W.J. Roberts and J.C. Simpkins. 1978. Thermal performance of a plastic film solar water heater. ASAE Paper No. 78-3507.
- Kreith, F. and J.F. Kreider. 1979. Principles of Solar Engineering. McGraw-Hill Book Co. New York, New York.
- Manning, T.O. 1979. Unpublished floor heating data. Interdepartmental communication.
- Mears, D.R., W.J. Roberts and J.C. Simpkins. 1974. New concepts in greenhouse heating. ASAE Paper No. NA74-112.
- Mears, D.R. and C.D. Baird. 1976. Development of a low cost solar heating system for greenhouses. Proceedings of the Solar Energy-Fuel and Food Workshop, Tucson, Arizona.
- Mears, D.R., W.J. Roberts, J.C. Simpkins, and P.W. Kendall. 1977. The Rutgers solar heating system for greenhouses. ASAE Paper No. 77-4009.
- Mears, D.R., W.J. Roberts, and P.W. Kendall. 1978. Development of a greenhouse solar heating demonstration. ASAE Paper No. 78-4512.
- Mears, D.R., W.J. Roberts, P.W. Kendall, and J.P. Cipolletti. 1979. Performance of the Kube Pak solar heated greenhouse. Proceedings of the 4th Annual Conference on Solar Energy for Heating of Greenhouses. Piscataway, New Jersey.
- Roberts, W.J. 1969. Heating and ventilating greenhouses. Biological and Agricultural Engineering Extension paper. College of Agriculture and Environmental Science, Rutgers-The State University. New Brunswick, New Jersey.
- Roberts, W.J. and D.R. Mears. 1969. Double covering a film greenhouse using air to separate film layers. Transactions ASAE Vol.12 No. 11.

- Roberts, W.J. 1970. Automatic black cloth shading for greenhouses. Biological and Agricultural Engineering Extension paper. College of Agriculture and Environmental Science, Rutgers-The State University. New Brunswick, New Jersey.
- Roberts, W.J., D.R. Mears, J.C. Simpkins and P.W. Kendall. 1976. Heating plastic greenhouses with solar energy. ASAE Paper No. NA76-102.
- Roberts, W.J. and D.R. Mears. 1978. Control system for a solar heated greenhouse. ASAE Technical Paper No. 78-5019.
- Roberts, W.J. and D.R. Mears. 1979. Floor heating of greenhouses. Biological and Agricultural Engineering Extension paper. Cook College, Rutgers-The State University. New Brunswick, New Jersey.
- Simpkins, J.C., D.R. Mears and W.J. Roberts. 1975. Reducing heat losses in polyethylene covered greenhouses. ASAE Paper No. 75-4022.
- Simpkins, J.C., D.R. Mears, W.J. Roberts, P.W. Kendall, T.O. Manning and J. Tecza. 1978. Progress in solar heating of plastic greenhouses. Proc. 3rd Annual Conf. on Solar Energy for Heating of Greenhouses. Fort Collins, Colorado.
- Walker, J.N. 1965. Predicting temperatures in ventilated greenhouses. Transactions of the ASAE Vol. 8(3).

PUBLICATIONS AND PRESENTATIONS RESULTING FROM SOLAR RESEARCH AT RUTGERS

1. Roberts, W. J. 1976. An energy saving naturally ventilated plastic greenhouse. ASAE Paper No. 76-4013.
2. Roberts, W. J., J. C. Simpkins and P. W. Kendall. 1976. Using solar energy to heat polyethylene film greenhouses. ASAE Paper No. 76-4011.
3. Roberts, W. J. 1976. Energy developments in the greenhouse industry. 1976 Grower Conference, Western Greenhouse Vegetable Growers' Association, Anaheim, California, July 21-23 (Invited paper).
4. Mears, D. R. and C. D. Baird. 1976. Progress in the development of practical solar greenhouse heating systems. Proceedings of the International Congress on Engineering and Food, Boston, Massachusetts. August 9-13.
5. Mears, D. R. 1976. Alternative heating. Foliage Plant School, The DuPage Horticultural School, West Chicago, Illinois. August 8-12.
6. Mears, D. R., W. J. Roberts, C. D. Baird and T. E. Bond. 1976. Use of solar energy for greenhouse heating. Proceedings of the 73rd Annual Meeting of the American Society for Horticultural Science, Baton Rouge, Louisiana. August 11-14 (Invited paper).
7. Mears, D. R. and W. J. Roberts. 1976. What's new in poly structures. Proceedings of the 26th Annual Meeting, International Plant Propagators Society, Cook College, Rutgers University, New Brunswick, New Jersey August 23-26 (Invited paper).
8. Roberts, W. J., D. R. Mears, J. C. Simpkins and P. W. Kendall. 1976. Heating plastic greenhouses with solar energy. ASAE Paper No. NA 76-102. August 15-18.
9. Simpkins, J. C., D. R. Mears and W. J. Roberts. 1976. Reducing heat losses in polyethylene greenhouses. Transactions of the ASAE 19(4).
10. Roberts, W. J. and D. R. Mears. 1976. Using solar energy for greenhouse heating. Proceedings of the International Solar Energy Society Conference on 'Solar Energy in Agriculture', University of Reading, England. September 13-15 (Invited paper).
11. Simpkins, J. C. 1976. Greenhouse construction and heat conservation. Virginia Flower Grower Meeting. Blacksburg, Virginia. October 12.
12. Roberts, W. J. 1976. Greenhouses in the next century. Bedding Plant Conference, Hershey, Pennsylvania. October 4-6.
13. Roberts, W. J. 1976. The Rutgers solar greenhouse project. New England Flower Growers Meeting. Chicopee, Massachusetts. October 18.
14. Roberts, W. J. 1976. Heating greenhouses with solar energy. Atlantic County Growers Meeting. New Jersey. October 21.

15. Roberts, W. J. 1976. The Rutgers solar greenhouse project. Bergen County Community College. New Jersey. November 19.
16. Roberts, W. J. 1976. The Rutgers solar greenhouse project. Brookdale Community College, Long Island, New York. December 4.
17. Roberts, W. J. 1976. Greenhouse research at Rutgers. One hour radio program, Asbury Park, New Jersey, December 8.
18. Mears, D. R. 1977. Energy supply and possible future. The 29th Annual Fieldman's Conference. The Ontario Food Processors' Association. Guelph, Ontario, Canada. January 5, 6.
19. Roberts, W. J. 1977. Heating plastic covered greenhouses with solar energy. South Jersey Greenhouse Vegetable Growers Association, Corbin City, New Jersey. January 6.
20. Simpkins, J. C. 1977. Studies in solar heating greenhouses. Hudson Valley Vegetable Program, Kerhonskon, New York. January 13.
21. Roberts, W. J. 1977. Energy conservation in greenhouses. North Carolina Vegetable Growers Association. Raleigh, North Carolina. January 18.
22. Roberts, W. J. 1977. Solar energy for heating plastic greenhouses. North Carolina Vegetable Growers Association. Raleigh, North Carolina. January 19.
23. Mears, D. R. 1977. New advances in greenhouse construction and energy conservation. Delaware Nurserymen, Dover, Delaware. January 27.
24. Mears, D. R. 1977. Heating greenhouses with solar energy. North Jersey Florists Meeting, Clifton, New Jersey. February 4.
25. Roberts, W. J. 1977. Sun, stones and water for heat. North Jersey Vegetable Growers Meeting, Hackettstown, New Jersey. February 8.
26. Mears, D. R., W. J. Roberts and C. D. Baird. 1977. Performance of a low-cost plastic film solar water heater. Proceedings of the Flat-Plate Solar Collector Conference, ERDA and Florida Solar Energy Center, Orlando, Florida. February 28-March 2.
27. Mears, D. R. 1977. A practical greenhouse solar heating system. Mechanical Engineering Colloquium, The College of Engineering, Rutgers University, New Brunswick, New Jersey. February 16.
28. Mears, D. R., W. J. Roberts and J. C. Simpkins. 1977. Performance of the New Jersey solar system for heating greenhouses. Proceedings of the Conference on Solar Energy for Heating Greenhouses and Greenhouse-Residential Combinations, Cleveland, Ohio. March 20-23.
29. Mears, D. R., W. J. Roberts and J. C. Simpkins. 1977. Solar energy and its utilization to heat greenhouses. Proceedings of the International Symposium on Controlled Environment Agriculture, Tucson, Arizona. April 7-8 (Invited paper)

30. Roberts, W. J. and D. R. Mears. 1977. Designs and considerations for greenhouses in the U.S., now and in the future. Proceedings of the International Symposium on Controlled Environment Agriculture, Tucson, Arizona. April 7-8 (Invited paper)
31. Roberts, W. J. and D. R. Mears. 1977. Using solar energy for greenhouse heating. Proceedings of the International Agricultural Plastics Congress, San Diego, California. April 11-16.
32. Mears, D. R., W. J. Roberts, J. C. Simpkins and P. W. Kendall. 1977. A low-cost plastic film solar water heater. Proceedings of the International Agricultural Plastics Congress, San Diego, California. April 11-16.
33. Mears, D. R., W. J. Roberts and J. C. Simpkins. 1977. Plastic film use in greenhouse heat exchangers. Proceedings of the International Agricultural Plastics Congress, San Diego, California. April 11-16.
34. Simpkins, J. C., D. R. Mears and W. J. Roberts. 1977. Greenhouse energy conservation. Proceedings of the International Agricultural Plastics Congress, San Diego, California. April 11-16.
35. Mears, D. R., and W. J. Roberts. 1977. Four-component solar system offers potential help with heating requirements, Florists Review, May 12.
36. Mears, D. R., W. J. Roberts and J. C. Simpkins. 1977. Performance of a practical solar greenhouse heating system. Proceedings of the 1977 Annual Meeting, American Section of the International Solar Energy Society, Orlando, Florida. June 6-10.
37. Eshleman, W. D., C. D. Baird and D. R. Mears. 1977. A numerical simulation of heat transfer in rock beds. Proceedings of the 1977 Annual Meeting, American Section of the International Solar Energy Society, Orlando, Florida. June 6-10.
38. Roberts, W. J. 1977. Energy conservation in greenhouses. Energy Conservation in the Greenhouse Extension Meeting, New Brunswick, New Jersey. June 14.
39. Mears, D. R. 1977. Using solar energy to heat greenhouses. Energy Conservation in the Greenhouse Extension Meeting, New Brunswick, New Jersey. June 14.
40. Simpkins, J. C. 1977. A look at solar energy for heating greenhouses. Hudson Valley Greenhouse Energy Conference, Millbrook, New York. June 14.
41. Mears, D. R., W. J. Roberts, J. C. Simpkins and P. W. Kendall. 1977. The Rutgers solar heating system for greenhouses. Annual Meeting of the ASAE, Raleigh, North Carolina ASAE Paper 77-4009. June 26-29.

42. Roberts, W. J. 1977. The future for solar energy in greenhouse application. Greenhouse Growers of Ohio, Columbus, Ohio. June (Invited paper).
43. Mears, D. R., W. J. Roberts, J. C. Simpkins and P. W. Kendall. 1977. The Rutgers solar heating system for greenhouses. North Atlantic section of the ASAE, Annual Meeting, Frederickton, New Brunswick, Canada ASAE Paper No. NA 77-401.
44. Mears, D. R., W. J. Roberts and J. C. Simpkins. 1977. Performance of a practical solar greenhouse heating system. Proceedings of the International Symposium on More Profitable Use of Energy in Protected Cultivation. International Society of Horticultural Sciences, Lund, Sweden. August 22-26 (Invited paper)
45. Roberts, W. J. and D. R. Mears. 1977. Design and considerations for greenhouses in the United States now and in the future. Proceedings of the International Symposium on More Profitable Use of Energy in Protected Cultivation. Proceedings of the International Society of Horticultural Sciences, Lund, Sweden. August 22-26 (Invited paper)
46. Roberts, W. J. 1977. Energy conservation and applicability of solar energy in greenhouses. Midwest Greenhouse Vegetable Conference, Toronto, Canada. September 26-28.
47. Roberts, W. J. 1977. Solar energy use in greenhouse heating. North Jersey Greenhouse Growers Conference. November 1.
48. Roberts, W. J. 1977. Energy conservation in greenhouses. South Jersey Nurserymen's Association. November 16.
49. Roberts, W. J. 1977. Solar energy workshop for Northeast Extension workers, Albany, New York. November 17-18.
50. Roberts, W. J. and J. C. Simpkins. 1977. Solar energy in greenhouse heating. Atlantic County Greenhouse Growers Conference. November 22.
51. Roberts, W. J. 1977. Energy conservation in greenhouses. Plant Propagators Conference, Columbus, Ohio. December 9.
52. Shen, Hwan and D. R. Mears. 1977. Computer simulation of warm floor greenhouse heating. The Winter Meeting of the ASAE, ASAE paper No. 77-4532 Chicago, Illinois. December 13-16.
53. Roberts, W. J. 1978. Energy conservation and solar energy. Living Industries Conference, Monticello, New York. January 11.
54. Roberts, W. J. 1978. Energy conservation and solar energy. New Jersey Vegetable Growers Meeting, Vineland, New Jersey. January 17.
55. Roberts, W. J. 1978. Energy conservation and solar energy. New Jersey Association of Nurserymen, Cherry Hill, New Jersey. January 26.
56. Roberts, W. J. 1978. Solar energy in greenhouse heating. Oregon State University Short Course, Portland, Oregon. January 31.

57. Roberts, W. J. 1978. Solar energy in greenhouse heating, Oregon State University Short Course, Portland, Oregon. February 1.
58. Roberts, W. J. 1978. Solar greenhouse heating, New Jersey Rhododendron Association, Princeton, New Jersey. February 8.
59. Roberts, W. J. 1978. Energy conservation and solar energy heating of greenhouse, North Jersey Vegetable and Flower Growers Short Course, Hackensack, New Jersey. February 14.
60. Roberts, W. J. 1978. Solar energy in agriculture. Princeton Agriculture Society, Pennington, New Jersey. February 23.
61. Mears, D. R. 1978. The Rutgers solar energy program, PIRG/CIT Lecture Series, New Brunswick, New Jersey. March 13.
62. Mears, D. R. 1978. Solar energy in agriculture, The Metropolitan Dairy Technology Society, Paramus, New Jersey. March 14.
63. Roberts, W. J. 1978. Solar energy in agriculture, Kiwanis-Farmer Dinner of Gloucester County, Paulsboro, New Jersey. March 16.
64. Simpkins, J. C., D. R. Mears, W. J. Roberts, P. W. Kendall, T. O. Manning, J. Tecza and S. A. Garrison. 1978. Progress in Solar Heating of Plastic Film Greenhouses. Proceedings of the Third Annual Conference on Solar Heating of Greenhouses and Greenhouse Rural Residence Combinations. Fort Collins, Colorado. April 2-5.
65. Mears, D. R., W. J. Roberts, P. W. Kendall and J. C. Simpkins. 1978. Construction of the Kube Pak Solar Heating Demonstration. Proceedings of the Third Annual Conference on Solar Heating of Greenhouses and Greenhouse Rural Residence Combinations, Fort Collins, Colorado. April 2-5.
66. Roberts, W. J. 1978. Solar heating of greenhouses. Soil Conservation Society Seminar, New Brunswick, New Jersey. April 18.
67. Ross, D. S., W. J. Roberts, R. A. Parsons, J. W. Bartok and R. A. Aldrich. 1978. Energy conservation and solar heating for greenhouses. NRAES-3 Publication of the Northeast Regional Agricultural Engineering Service, May.
68. Roberts, W. J. and D. R. Mears. 1978. Control system for a solar heated greenhouse. ASAE Paper 78-5019, Utah State University, Logan, Utah. June 27-30.
69. Roberts, W. J. 1978. Energy conservation in greenhouses. Annual Meeting, Long Island Nurserymen's Association, Farmingdale, New York. July 10.
70. Roberts, W. J. 1978. Energy conservation and solar heating of greenhouses. Nurserymen's Field Day, Laurel, New York. July 11.

71. Roberts, W. J. and D. R. Mears. 1978. Solar heating system for a 0.54 hectare greenhouse. Proceedings of the International Symposium on Potential Productivity in Protected Cultivation, ISHS, Tokyo, Japan. August 28-September 2 (Invited paper).
72. Roberts, W. J. and D. R. Mears. 1978. Energy conservation in greenhouses in the U.S.A. Proceedings of the International Symposium on Potential Productivity in Protected Cultivation, ISHS, Tokyo, Japan. August 28-September 2 (Invited paper).
73. Roberts, W. J. 1978. Use of solar energy for heating greenhouses. Lecture at the University of Chiba, Matsudo, Japan. September 16. (Invited paper).
74. Simpkins, J. C. 1978. The Rutgers solar greenhouse heating system. Greater Philadelphia Orchid Society, Philadelphia, Pennsylvania, September 2.
75. Roberts, W. J. 1978. Use of solar energy for heating greenhouses. Lecture at the University of Tokyo, Tokyo, Japan. September 23.
76. Roberts, W. J. 1978. Update on energy conservation. Proceedings of the Eleventh International Bedding Plant Conference, Toronto, Canada. October 1-5.
77. Roberts, W. J. 1978. Update in solar energy. Proceedings of the Eleventh International Bedding Plant Conference, Toronto, Canada. October 1-5.
78. Mears, D. R., W. J. Roberts, P. W. Kendall and J. C. Simpkins. 1978. Construction of the Kube Pak solar heating demonstration. Proceedings of the Solar Industrial Process Heat Conference, Denver, Colorado. October 18-20.
79. Simpkins, J. C. 1978. Solar energy for greenhouses. Nova Scotia Greenhouse Growers Association, Halifax, Nova Scotia, Canada. October 25-27.
80. Roberts, W. J. and D. R. Mears. 1978. A large solar heated greenhouse demonstration facility. Proceedings of the 14th Annual Plastics Congress, Miami Beach, Florida. November 10-13.
81. Kendall, P. W., D. R. Mears, W. J. Roberts and J. C. Simpkins. 1978. Thermal performance of a plastic film solar water heater. Annual Meeting of the American Society of Agricultural Engineers, Chicago, Illinois. December 18-20. ASAE paper No. 78-3507
82. Mears, D. R., W. J. Roberts and P. W. Kendall. 1978. Development of a greenhouse solar heating demonstration. Annual Meeting of the American Society of Agricultural Engineers, Chicago, Illinois. December 18-20. ASAE paper No. 78-4512

83. Mears, D. R. and W. J. Roberts. 1978. Solar heating of commercial greenhouses - Kube-Pak Garden Plants Inc., Final Report, Phase IV, Construction. Prepared for USDOE under contract No. EG-77-C-05-5454. December.
84. Roberts, W. J. and D. R. Mears. 1979. Using solar energy for greenhouse heating. Ohio Florists Assn. Bulletin No. 592. February.
85. Mears, D. R., Editor. 1979. Proceedings, Fourth Annual Conference on Solar Energy for Heating Greenhouses and Greenhouse-Residence Combinations, Piscataway, New Jersey. April 1-4, 214 pp.
86. Roberts, W. J., J. C. Simpkins, H. W. Janes and D. R. Mears. 1979. Performance of the Rutgers solar heated greenhouse vegetable facility. ASAE Paper No. 79-4032, presented at the Summer Meeting of the ASAE and CSAE, Winnipeg, Canada. June 24-27.
87. Kendall, Paul W. 1979. Thermal performance of a plastic film solar collector. M.S. Thesis, Biological and Agricultural Engineering Department, Rutgers University, Cook College, New Brunswick, New Jersey. June.
88. Roberts, W. J. 1979. Solar greenhouses and energy conservation. New Jersey Greenhouse Growers Conference and Field Day, Moorestown, New Jersey. July 25.
89. Simpkins, J. C. 1979. Greenhouse energy conservation. New Hampshire Greenhouse Growers, Dover, New Hampshire. August 1.
90. Mears, D. R. 1979. Future energy conservatiuon systems and utilization of waste heat. Greenhouse Energy Management School, Cincinnati, Ohio. September 5.
91. Mears, D. R. 1979. Television show, 'Solar energy utilization in greenhouses.' Perspective - New Jersey, ABC TV, Philadelphia, Pennsylvania. September 23.
92. Mears, D. R. 1979. Use of plastics in solar energy. Alumni Reunion Seminar, Department of Mechanics and Materials Science, College of Engineering, Rutgers University, New Brunswick, New Jersey. October 19.
93. Roberts, W. J. 1979. Long Island Growers Tour of Rutgers Solar Energy Research and Demonstration Projects. October 23.
94. Roberts, W. J. and D. R. Mears. 1979. College for a Day - Cook College, Rutgers University, New Brunswick, New Jersey. November 15.
95. Simpkins, J. C. 1979. Solar Greenhouse Tour, Garden Club of New Jersey Horticultural School. November 15.
96. Roberts, W. J. 1980. Bottom heating of greenhouses. New Jersey Vegetable Growers Meeting, Atlantic City, New Jersey. January 15-16.

97. Roberts, W. J. 1980. Energy conservation in greenhouses. New Jersey Vegetable Growers Meeting, Atlantic City, New Jersey. January 15-16.
98. Mears, D. R. 1980. Solar heated greenhouses for horticultural production. Solar Energy for the 80's Conference, Cabrillo College, Aptos, California. January 20.
99. Roberts, W. J. 1980. Solar energy and energy conservation in greenhouses. New Jersey Greenhouse Growers Meeting. January 24.
100. Roberts, W. J. 1980. Solar energy in agriculture. New Jersey Lawn and Agricultural Farm Equipment Dealers Association. January 25.
101. Mears, D. R. 1980. Heat conservation in greenhouses. National Tropical Foliage Short Course, Orlando, Florida. January 29.
102. Roberts, W. J. 1980. Solar energy and energy conservation in greenhouses. New Jersey Association of Nurserymen, Atlantic City, New Jersey. February 4.
103. Roberts, W. J. 1980. Solar energy and energy conservation in greenhouses. New Jersey Greenhouse Growers Meeting. February 8.
104. Mears, D. R. 1980. Solar energy and greenhouses. New Jersey Conservation Club.
105. Roberts, W. J. 1980. Solar energy in greenhouses. New Jersey Flower Show, Morristown, New Jersey, March 7.
106. Roberts, W. J., D. R. Mears and H. Janes. 1980. Performance of the Rutgers solar heated greenhouse vegetable facility. Proceedings of the 15th National Agricultural Plastics Congress, Tucson, Arizona. April 13-17.
107. Roberts, W. J. and D. R. Mears. 1980. Use of plastic pipe for floor heating of greenhouses. Proceedings of the 15th National Agricultural Plastics Congress, Tucson, Arizona. April 13-17.
108. Mears, D. R., P. W. Kendall, W. J. Roberts, J. P. Cipolletti, J. C. Simpkins and H. W. Janes. 1980. The Rutgers system for solar heating of commercial greenhouses. Proceedings of the 1980 Annual Meeting of AS/ISES, Phoenix, Arizona. June 2-6.
109. Mears, D. R. 1980. Residential application of the Rutgers system for solar heating of greenhouses. Proceedings of the 1980 Annual Meeting of AS/ISES, Phoenix, Arizona. June 2-6.
110. Roberts, W. J. and D. R. Mears. 1980. Research on conservation and solar energy utilization in greenhouses. ASHRAE Annual Meeting, Denver, Colorado. ASHRAE Transactions 86, 2. June 22-25.
111. Roberts, W. J. and D. R. Mears. 1980. Floor heating of greenhouses. ASAE Paper No. 80-4027. San Antonio, Texas. June 15-18.

112. Manning, T. O., D. R. Mears, R. McAvoy and B. Godfriaux. 1980. Waste heat utilization in the Mercer research greenhouse. ASAE Paper No. 80-4031. San Antonio, Texas. June 15-18.
113. Television program on the Kube Pak project. WORTV Ch 9, New York. Appeared on '9 on New Jersey.'
114. TV News Report on the Rutgers Solar Heating System for Greenhouses was filmed at Kube Pak and shown on 'New Jersey Nightly News,' NJPTV Channels 23, 52, 56, and 58.
115. TV Solar Energy in New Jersey, Half hour TV segment for WABCTV Ch 7, New York, Series 'New Jersey, Search for Solutions.'
116. Manning, T. O. 1980. Evaluation of a prototype greenhouse designed for utilization of waste heat. M.S. Thesis, Agricultural Engineering Department, Rutgers University, Cook College, New Brunswick, New Jersey. June.
117. Cipolletti, J. P. 1980. Performance of the Kube Pak greenhouse solar heating demonstration project. M.S. Thesis, Agricultural Engineering Department, Rutgers University, Cook College, New Brunswick, New Jersey. June.
118. James, M. F., 1980. Thermal performance of embedded pipe porous concrete floor heating systems for greenhouse use. M.S. Thesis, Agricultural Engineering Department, Rutgers University, Cook College, New Brunswick, New Jersey. June.
119. Mears, D. R. 1980. Solar energy in commercial greenhouses. Presented to Vermont Energy Group, Montpelier, Vermont. July 31.
120. Manning, T. O., D. R. Mears, R. McAvoy and B. Godfriaux. 1980. Feasibility of waste heat utilization in greenhouses. ASAE Paper No. NAR 80-401, Willimantic, Connecticut. August 3-6.
121. Cipolletti, J. P., D. R. Mears, W. J. Roberts and P. W. Kendall. 1980. A study of energy flows within a commercial greenhouse application of the Rutgers solar greenhouse heating system. ASAE Paper No. 80-402, Willimantic, Connecticut. August 3-6.
123. Roberts, W. J., D. R. Mears. 1980. Energy conservation and new energy sources in the greenhouse. Montreal, Canada. August 22.
124. Manning, T., D. Mears, R. McAvoy, and B. Godfriaux. 1980. Waste heat utilization in the Mercer research greenhouse. Foliage Digest, Vol. III, No. 8, Apopka, Florida. September.
125. Mears, D.R. and W.J. Roberts. 1980. Energy use in greenhouses - how low can we go? 1980. Acta Horticulturae 115, Invitational Keynote paper, International Symposium on More Profitable Use of Energy in Protected Cultivation, Dublin, Ireland, September 7-12.

126. Mears, D. R., W. J. Roberts, J. C. Simpkins, P. W. Kendall, J. P. Cipolletti and H. Janes. 1980. The Rutgers system for solar heating of commercial greenhouses. *Acta Horticulturae* 115. International Symposium on More Profitable Use of Energy in Protected Cultivation, Dublin, Ireland. September 7-12.
127. Manning, T. O., D. R. Mears, R. McAvoy and W. J. Roberts. 1980. The flooded floor for waste heat utilization in greenhouses. *Acta Horticulturae* 115, International Symposium on More Profitable Use of Energy in Protected Cultivation, Dublin, Ireland. September 7-12.
128. Roberts, W. J., D. R. Mears and M. James. 1980. Floor heating of greenhouses. *Acta Horticulturae* 115, International Symposium on More Profitable Use of Energy in Protected Cultivation, Dublin, Ireland. September 7-12.
129. Roberts, W. J., D. R. Mears. 1980. Progress in movable blanket insulation systems for polyethylene-covered greenhouses. *Acta Horticulturae* 115, International Symposium on More Profitable Use of Energy in Protected Cultivation, Dublin, Ireland. September 7-12.
130. Roberts, W. J. and D. R. Mears. 1980. Air-inflated plastic film greenhouses. *Acta Horticulturae* 115, International Symposium on More Profitable Use of Energy in Protected Cultivation, Dublin, Ireland, September 7-12.
131. Janes, H. W., R. McAvoy, M. Maletta, J. C. Simpkins and D. R. Mears. 1980. The effect of warm root zone temperatures on growth of tomato and poinsettia. *Acta Horticulturae* 115, International Symposium on More Profitable Use of Energy in Protected Cultivation, Dublin, Ireland, September 7-12.
132. Roberts, W. J. Grower Energy Conservation Seminar and Field Trip. Pompton Plains, New Jersey. September 23, 1980.
133. Roberts, W. J. and D. R. Mears. 1980. Floor heating of greenhouses. 'Agricultural Energy' Proceedings of the ASAE National Energy Symposium, Kansas City, Missouri. September 29 to October 1.
134. Mears, D. R., W. J. Roberts, J. P. Cipolletti and P. W. Kendall. 1980. The Kube-Pak commercial greenhouse demonstration project. 'Agricultural Energy' Proceedings of the ASAE National Energy Symposium, Kansas City, Missouri. September 29 to October 1.
135. Roberts, W. J., D. R. Mears, J. C. Simpkins and J. P. Cipolletti. 1980. Movable thermal insulation for greenhouses. 'Agricultural Energy' Proceedings of the ASAE National Energy Symposium, Kansas City, Missouri. September 29 to October 1.
136. Mears, D. R. 1980. Residential application of the Rutgers system for solar heating of greenhouses. Abstract in 'Agricultural Energy' Proceedings of the ASAE National Energy Symposium, Kansas City, Missouri. September 29 to October 1.

137. Mears, D. R., W. J. Roberts, J. C. Simpkins and R. Janes. 1980. Rutgers research on solar heating of greenhouses. 'Agricultural Energy' Proceedings of the ASAE National Energy Symposium, Kansas City, Missouri. September 29 to October 1.
138. Manning, T. O., D. R. Mears, R. McAvoy, and B. Godfriaux. 1980. Waste heat utilization in the Mercer research greenhouse. 'Agricultural Energy' Proceedings of the ASAE National Energy Symposium, Kansas City, Missouri. September 29 to October 1.
139. LePoidevin, R. E. 1980. A prototype heat exchanger for humidity control in greenhouses. M.S. Thesis, Agricultural Engineering Department, Cook College, Rutgers University, New Brunswick, New Jersey. October.
140. Roberts, W. J. and D. R. Mears. 1980. Warm water solar systems bring greenhouse savings. USDA Yearbook, Section 4, Chapter 5-B.
141. Bartok, J. and W. J. Roberts. 1980. Greenhouse failures in the Northeast. ASAE Paper No. 80-4002. San Antonio, Texas. June 15-18.
142. Roberts, W.J. and D.R. Mears. 1981. Using solar energy for greenhouse heating. Growing Profits, Newsletter of Wholesale Nursery Growers of America. Washington D.C. February.

MANUAL FOR COLLECTOR CONSTRUCTION

SITE LOCATION

1. Situate collector close to greenhouse.
2. Site chosen must allow collector and greenhouse an unobstructed exposure to the southern sky.
3. The supply and return lines between the greenhouse and collector should slope approximately 1/4" per foot.
4. If possible, the land should not slope more than 1' in 100' in the east/west direction. Otherwise, the land should be graded or the solar collector footing plans altered.
5. In the case of multiple collectors, one in front of the other, enough distance should be left between collectors, so the front collector will not shade the face of the rear one when the sun is at its lowest point at solar noon on December 21. Shadows from trees and structures should be avoided. Distance between collectors varies with slope of land and latitude.
6. The hole locations for the front and rear posts should be marked 8' on centers and dug to at least the minimum depth indicated on the plans (Sheet 2).

SHOP WORK

Posts

1. Front posts are cut to the desired length, observing the 33" minimum in-ground and 30" maximum above-ground guideline. For the rear posts, the in-ground minimum is the same, but the above-ground maximum is 9" (Sheet 2).
2. Drill the holes for the 1/2" bolts so the center is 1" below the top of the post.
3. Weld on the rod or angle iron or drill a hole for a 3/8"x6" bolt 12" to 18" from the bottom of each post. If a bolt is to be used, insert it at this time.

Angle Iron

1. Cut and drill 3"x3"x5/16" steel angle as per plan (Sheet 3).

Steel Plates

2. Cut and drill 18 ga. galvanized steel straps, plates and caps as per plan (Sheets 3 and 4).
 - a. 1 type of cap
 - b. 2 types of straps
 - c. 1 type of plate

3. As an alternative to #1, purchase TECO connectors or equivalent and drill the 1/2" hole in the cap and plates.

Lumber

1. Paint all lumber with white exterior latex paint.
2. Cut all pieces to required length.
 - a. Type I; 2"x4"x12" spacers (Sheet 2); also nail together with 10 d nails at this time
 - b. Type II; (2) 2"x4" or 4"x4"x12" spacers (Sheet 2); also nail together with 10 d nails at this time if required
 - c. Type III; (2) 2"x4" or 4"x4"x8" spacers (Sheet 2); also nail together with 10 d nails at this time if required
 - d. 2"x4"x8" arm spacers (Sheet 4)
 - e. 2"x4"x10" brace spacers (Sheet 3)
 - f. 2"x4"x8" spacers for plywood scaffold plank supports (Sheet 2)
 - g. 1/2" exterior grade plywood scaffold plank supports (Sheet 2)
3. Connect 18 ga. steel caps to arms and braces (Sheet 4, Det. D; Sheet 3, Det. B) and drill holes in lumber for 1/2" dia. bolts; do not connect 18 ga. steel plates to rear post end of arms or braces at this time. This is to be done in the field.
4. Assemble double 14' rafters per plan, being sure the plates for the front posts, braces, and arms are in place, along with the brace and arm spacers and the holes for the 1/2" bolts are drilled in the lumber before the two 2"x4"x14' rafters are nailed together through the type I, II and III spacers.

Note: Spacer type I is installed so the rafter will have a 3" space. Spacers #II and III are installed to provide a 3-1/2" space (Sheet 2).

SITE CONSTRUCTION

Posts

1. Lines sloping 4" in 100' and at the proper locations and heights should be located over the front and rear holes to ensure their correct post installation. Pull tightly to eliminate as much sagging as possible. After post holes are dug to the proper depth and in the correct location, the posts should be placed in the holes. If the posts are long enough, they may be driven 6" or so past the bottom of the hole to help secure them during the pouring of the concrete. The string will aid in this procedure.

2. Once all posts are in the holes, pour the concrete and tamp it to ensure no large air spaces are left in the mix. Make only fine adjustments to post height and location at this time as the post may be quite difficult to reposition due to the rod that was previously welded on. Use the line to be sure the holes in the pipes are all aligned with each other east and west. THIS IS IMPORTANT!! All pipes should now be in place as indicated on Sheets 1 and 2.
3. Allow time (2 days) for the concrete to set, then proceed with assembly of the collector.

Collector Frame Assembly

1. Install rafters and left and right angle iron pieces on front posts and connect with the 1/2"x7-1/2" bolt, nut and washers (Sheet 3, Det. A).
2. Lift rafters off the ground about 6' at the upper end and install the arm and brace on each one (Sheet 2 and Det. B & D). Once the arm and brace are in place, raise the rafter to the desired permanent angle (45°, 55°, 65°, etc.) and mark where the plates should be located on the lower ends of the arm and brace as determined by the rear post.

Note: When the brace and arm are being marked for drilling and plate attachment, be sure the top of the rafter is positioned directly over the rear post and that the rear and front post are aligned. If this is not done, the holes in the brace and arm will not line up with those in the rear post after the header has been installed! Some of the braces or arms may be too long to line up with the hole in the rear post. These must be cut to the proper length prior to marking.

3. Lower the rafters again after each one has had its arm and brace marked, until the top is about 6' above ground level and hold it there with the arm or brace or some other piece of lumber.
4. Begin attaching the header to the rafters at one end, making sure the center tops of the rafters are 8' o.c. (Sheet 1). Start with a single 2x4 at first and nail through it into the ends of the double rafters using 10 d nails. Once the first set of 2x4's has been attached the entire length, the second set is nailed to the first with 10 d nails, being sure that the joints are staggered (Sheet 1).
5. Now attach the steel straps that hold the header to the rafters (Sheet 4, Det. D). They should be tight.
6. At this point, install the gutter. Begin by attaching the 2x6 to the angle iron with the 5/16"x2" carriage bolts (Sheet 3, Det. A). Be sure the 2x6's butt one another over a post before drilling the holes so the angle iron will help to hold the gutter together, and that the 2x6 overhangs the end rafter (Sheet 1). Now temporarily nail the 2x8 gutter parts to the 2x6's that are already in place with 10 d nails every 3' or so. Be sure to follow the details on Sheet 1. Using a drill guide, drill the holes for the 1/2" lag screws through the 2x8 and into the 2x6. Then attach them with the 1/2"x5 lags. The 2x8's should butt at a different location than the 2x6's (Sheet 1). Nail metal straps between lag screws as shown on Sheets 1 and 3. Note:

Unless the hole is drilled straight into the 2x6, the 2x6 may split when the 1/2"x5" lag screws are installed.

7. Raise the collector approximately to its permanent position and attach the plates to and drill the holes in the arm and brace using the marks already obtained.
8. Attach the brace and legs to the rear post with the 6-1/2"x1/2" bolt (Sheet 3, Det. C).
9. Attach scaffold plank supports as shown on Sheet 2. Connect scaffold planks to supports with 16 d nails.
10. Attach end braces after collector has been squared to prevent east-west instability (Sheet 1). The frame is now complete.

Covering the Collector

1. Cut the vinyl for the gutter and end rafters and secure it temporarily with staples at a location that will not cause it to leak after the polylock is attached.
2. Attach the two strips of polylock to the gutter with the 1/4"x20x2" hex head bolts as indicated in Detail A, Sheet 3.
3. Attach the polylock strips to the end rafters with the #14x1-1/2" round head wood screws and apply the silicone sealer to prevent leaking (Det. E, Sheet 4).

Note: The vinyl near the gutter should be connected, so any water running down it will enter the gutter and not leak out onto the ground.

4. Fasten the two rows of locking strip to the top header with the #14x1-1/2" round head screws (Det. D, Sheet 4).
5. Cut the vinyl batten strip into 18" long pieces.
6. Drill the 3/32" holes, 6" on centers, in the 1-1/2" polyethylene pipe using any print on the pipe as a guide. Start drilling 3" from the end to be capped and drill 95.5' of pipe (192 holes). There should be about 4' undrilled at the other end. Flush pipe and check holes for any chips or foreign matter that may clog them. Install the plug in one end and wrap it so it will not tear the plastic.
7. Lay out the polylock inserts for all the strips around and on top of the collector.
8. It must be calm in order to cover the collector - NO WIND! Weather permitting, either unroll a clear 6-mil 16'x100' tube on the ground, unfold it and pull one edge to the top of the collector and staple it temporarily to the header on the wood between the two locking strips (Sheet 4, Det. D); OR lift the roll to the scaffold and place it on the header; unroll it on the header, stapling one edge to the header (between the two locking strips) as you go. Staple once every foot and

keep the edge even and tight as you go along. Leave about 1'-2' extra at the starting end so the material covers the collector from end to end.

9. Once the clear tube is stapled to the header the entire length of the collector, go along the bottom and be sure all folds and creases are out of it and that it overhangs the gutter about the same distance everywhere. Don't pull too hard on it at this point as the staples may tear out. Trim off the excess so it overlaps the bottom polylock strip about 4".
10. Unroll the 4 mil black plastic along the top of the header and staple it to the header in the same section the clear tube was stapled, but staple every 18" and put the staple through one end of a vinyl batten strip and then the black plastic. Each of these staples then goes through the batten strip, the black plastic, and the clear tube. The black should be completely unfolded and straightened out as much as possible during and after stapling.
11. The male polylock can now be installed in the header locking strip that is on the face of the collector. It should hold the rear clear tube and the black plastic sheet; DO NOT try to insert the vinyl batten strip in the polylock; the polylock cannot accept that much material.
12. Pull the rear clear sheet as tight as you can by hand at the gutter and lock it in the polylock strip on the back edge of the gutter (Sheet 3, Det. A). DO NOT lock the black plastic sheet in. Lock the clear tube in at the edges at this time, using the inner piece of polylock strip (Sheet 4, Det. E). Trim the clear tube and black plastic sheet, so they don't quite reach the inside bottom of the gutter, and don't block waterflow.
13. Staple the polypropylene mesh at about the same point as the vinyl batten strip, but underneath it. The staple should go through the batten strip and then the mesh, black poly and clear poly: all above the polylock strip that holds the clear and black poly.
14. Lift the 1-1/2" plastic pipe to the scaffold. Picking it up to the header as you go along, place it on top of the vinyl batten strap and pull the free end of the strap up toward the header so it supports the pipe as shown on Sheet 3, Det. D. Leave enough slack in the strap so the 1-1/2" pipe hangs down about 2"-3" below the rear tube polylock strip, then staple the free end of the strap to the header right next to the already stapled end. Before stapling, check to be sure the strap will not cover a hole in the pipe. If it does, then adjust the free end location of the strap to remedy this. After the pipe is completely supported, rotate it so the holes are in a plane parallel to the collector face; this will ensure that water is free to flow from the pipe at all locations. The capped end of the pipe should be about 2" from one end of the collector and the undrilled end should extend about 4' past the far end of the collector. The 4' undrilled section should be at the end where the collector supply line is to be located.

15. The front clear tube can now be installed, following the unrolling procedure that was used for the rear tube, except it need not be stapled at the top since the polylock is put in right away. Do the top polylock first, then pull all wrinkles and folds out of the tube. Pulling it as tight as possible by hand, install the gutter polylock and last install the polylock on each end.
16. Mount the inflation fans as shown on Sheet 5. Install the corrugated sump pipe in the rear tube by carefully cutting a small 'T' shape in the bottom plastic layer only, about 1' from the collector end and as high as required and then pushing the tube into the cut. Tape the tube to the plastic at the location of the cut. The front tube can be slipped in between the two front plastic layers directly above the gutter since it hasn't been clipped into the polylock at this location; NO CUTTING IS REQUIRED. The front tube is now stapled into the top or end of the gutter and the extra vinyl that was left to form the dam is lifted and folded over the polyethylene tube and stapled to the top of the gutter. The front and rear tubes must be taped, folded and stapled to the frame at the other three corners to be sure there will be no large air leaks. The fans are then plugged in and the pressure in the front and rear tubes adjusted to 0.15-0.20" of water. The pressure in the rear tube should be slightly higher than that in the front to ensure a convex black plastic surface for the water to flow over. A concave surface is not desirable since the water will just flow to the lowest point and channel down in very narrow strips.
17. The plumbing from the greenhouse floor storage to the 1-1/2" distributor pipe in the collector is connected. It is critical that the 2" supply line slope back into the greenhouse to ensure it will drain completely when the pump shuts off; otherwise, water remaining in the line may freeze and cause damage or prevent water from reaching the collector when the pump comes on.
18. The return pipe is installed at the drain end of the collector as shown on Sheet 5. The pipe must slope back to the greenhouse floor storage at all points so it drains completely when the pump is off.
19. One differential thermostat sensor is installed between the two layers of the front tube about 2' down from the header near the center of the collector. The other sensor is installed at least 2' from any edge of the floor storage and half way down in the rock water mixture.
20. Once the electrical wiring between the differential thermostat and the pump is completed, the collector is operational.

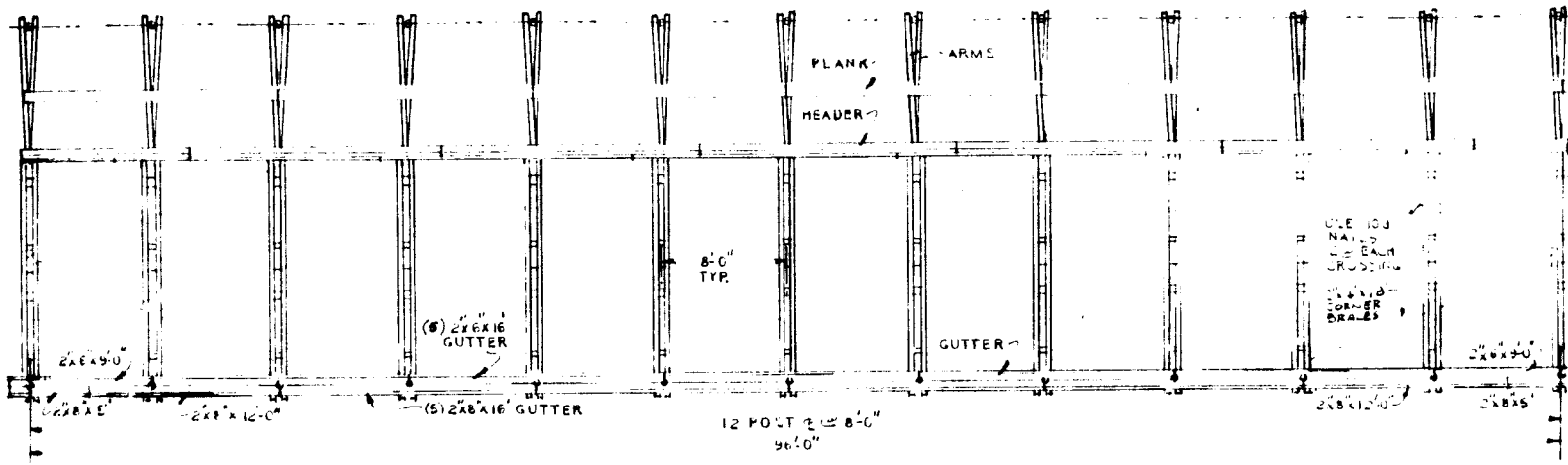

PLAN - NOT TO SCALE

DOUBLE 2x4 HEADER STAGGER JOINTS
 TOP ROW START 10' PG. 5 & 11' & LAST PG. 2'
 BOTT. " START 8' PG. 2 & 10' & LAST PG. 10'

WHERE NECESSARY
 AT CORNERS
 PULL & STAPLE POLY.
 TUBES TO MAINTAIN
 INFLATED AIR

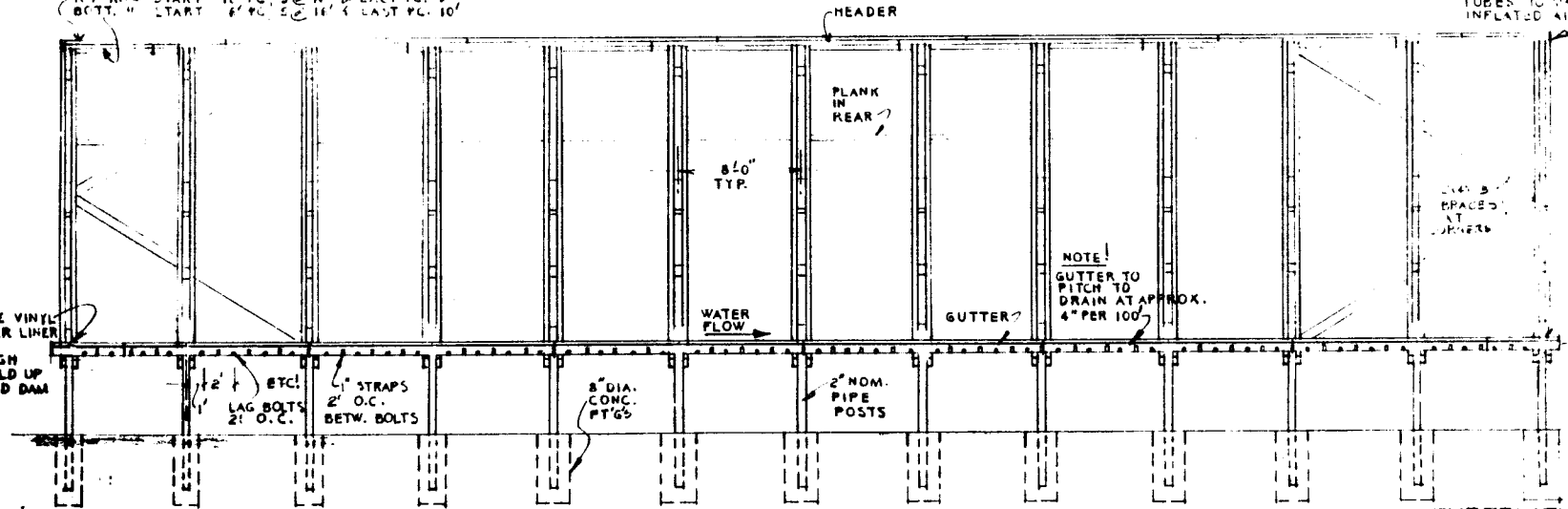

ELEVATION - NOT TO SCALE

NOTE!
 LEAVE VINYL
 GUTTER LINER
 LONG
 ENOUGH
 TO FOLD UP
 AN END DAM

NOTE!
 TOP ELEV. OF LEFT END PIPE
 TO BE 4" HIGHER THAN RIGHT
 END PIPE. EACH PIPE APPROX.
 1 1/2" LOWER THAN PREVIOUS
 REAR PIPES TO SLOPE SAME WAY

EXPERIMENTAL

TITLE SOLAR COLLECTOR X
 FIXED WOODEN
 RUTGERS - The State University
 COLLEGE of AGRICULTURE
 Dept. of Agricultural Engineering

REV. 7-17-79

DRN BY RUIZ DRAWING NO. C-10934 SHEET 1 OF 1
 DATE 10-30-78 SCALE

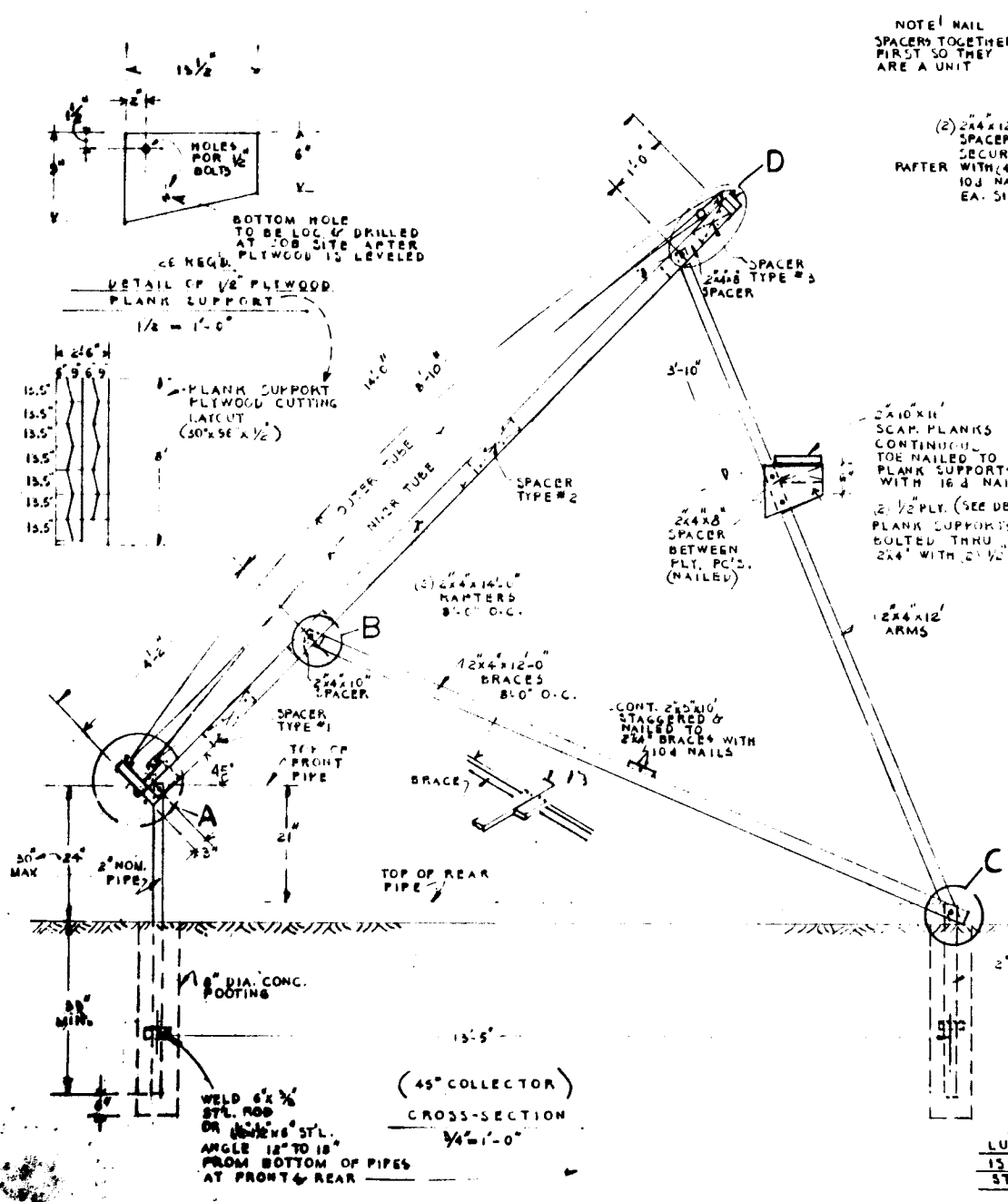

NOTE! NAIL SPACERS TOGETHER FIRST SO THEY ARE A UNIT

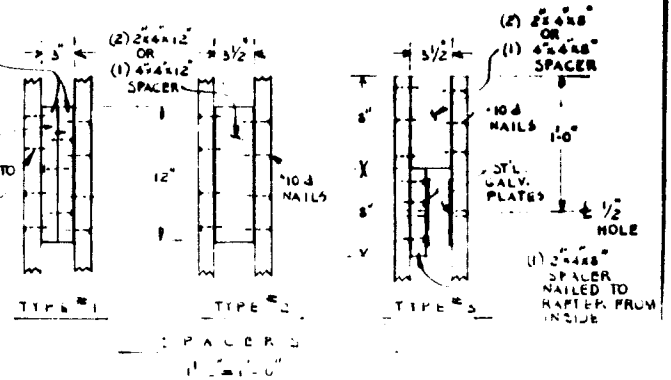

2x10x11 SCAM PLANKS CONTINUOUS TOE NAILED TO PLANK SUPPORTS WITH 16d NAILS
 2 1/2" PLY. (SEE DET. ABOVE LEFT)
 PLANK SUPPORTS BOLTED THRU 2x4' WITH 2 1/2" BOLTS x 3 1/2"

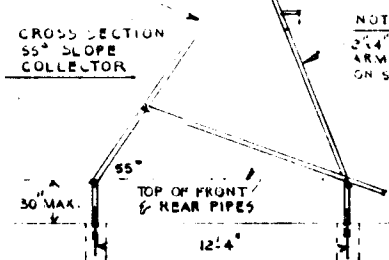
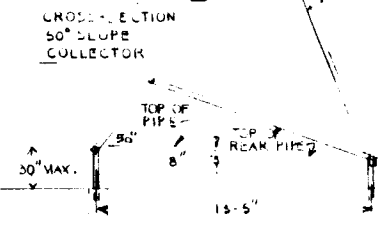

NOTE!
 2x4x12x8 ARMS REQ'D. ON 55° COLLECTOR ONLY

NOTE!
 LUMBER TO BE USED
 15 DOUGLAS FIR
 STRUCTURAL GRADE

EXPERIMENTAL
 TITLE SOLAR COLLECTOR II
 FIXED WOODEN
 RUTGERS - The State University
 COLLEGE of AGRICULTURE
 Dept. of Agricultural Engineering

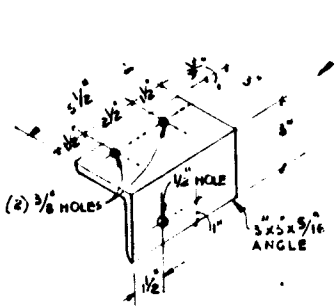

STEEL ANGLE DETAIL
26 REQ'D. TOTAL
13-AS SHOWN
13-OPPC. HAND

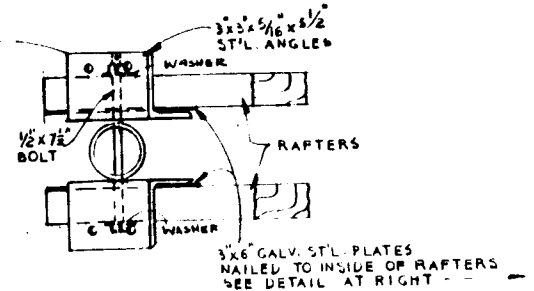

TOP VIEW (GUTTER EXCLUDED)

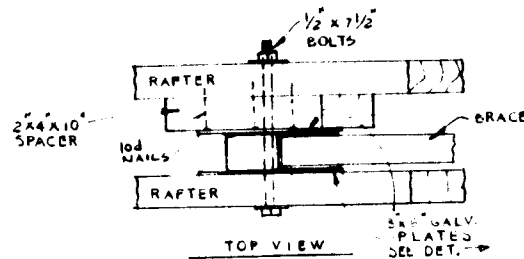

TOP VIEW

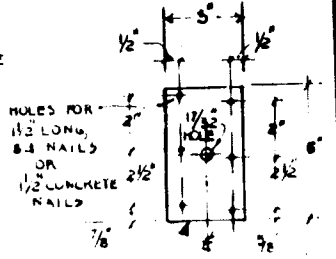

GALV. PLATE DETAIL

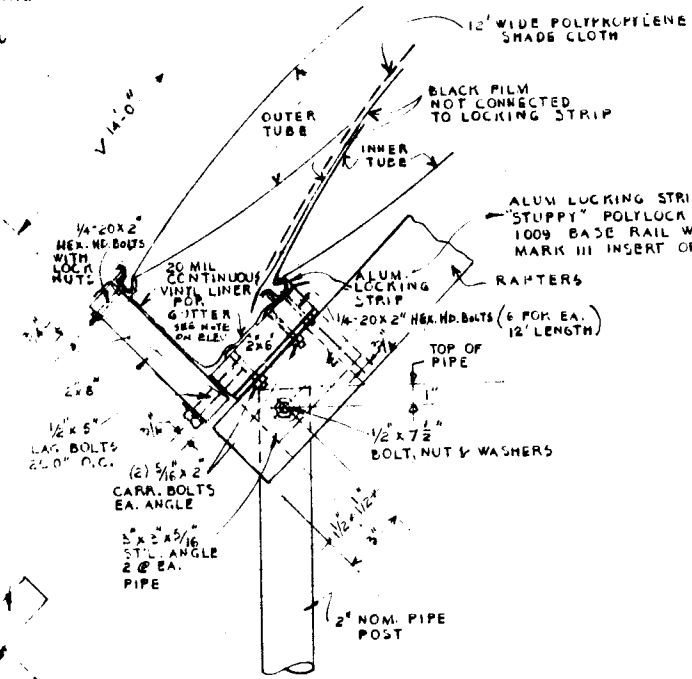

NOTE!
USE 16\"/>

ALUM. LOCKING STRIPS ARE "STUPPY" POLYLOCK EXTRUSION (12\"/>

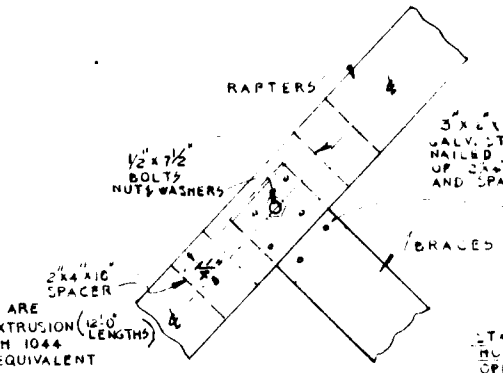

DETAIL - B
3\"/>

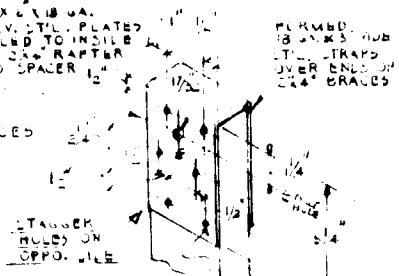

DETAIL OF FORCED GALV. CAPS

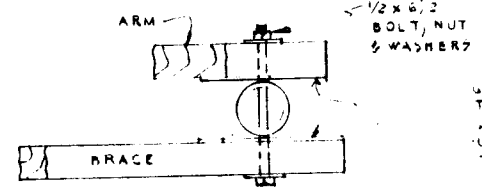

TOP VIEW

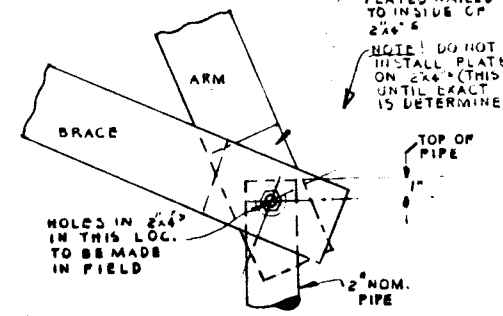

DETAIL - C
3\"/>

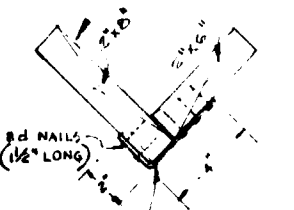

DETAIL - A
3\"/>

NOTE!
TECO STRAP-TIS CAN BE USED IN LIEU OF STRAP SHOWN (6\"/>

WIDE X 18 GA. GALV. STEEL STRAPS 240\"/>

NOTE! ALTERNATIVE PLATE CAP GALV. PLATE MAY BE REPLACED WITH TRUSS PLATE (NAILED TOP) OR GALV. CAP WITH TECO STRAP-TIS U-SHAPE AS SHOWN ABOVE. TECO ALSO APPLIED 1/2\"/>

EXPERIMENTAL

TITLE SOLAR COLLECTOR I
FIXED WOODEN

RUTGERS - The State University
COLLEGE of AGRICULTURE
Dept. of Agricultural Engineering

DRAWN BY RUIZ DATE 10-30-78 DRAWING NO. C-10934

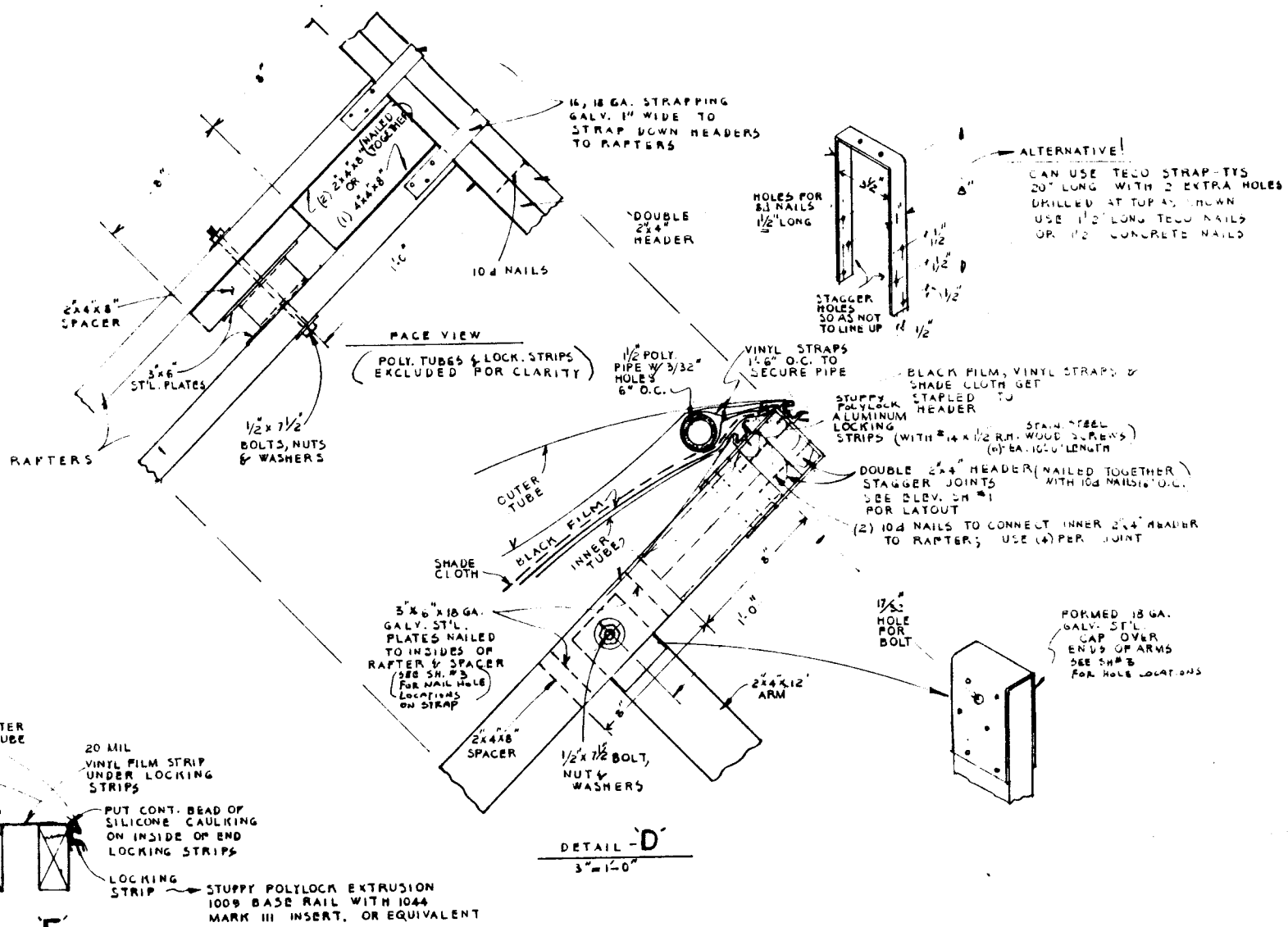

EXPERIMENTAL

TITLE SOLAR COLLECTOR **X** FIXED WOODEN

RUTGERS - The State University
COLLEGE of AGRICULTURE
Dept. of Agricultural Engineering

DRAWN BY RUIZ DRAWING NO. DATE 10-30-78 C-10954

REV. 7-17-79

WHERE NECESSARY IN FOUR CORNERS HOLD STAPLE POLY COVERS TO HOLD INFLATED AIR

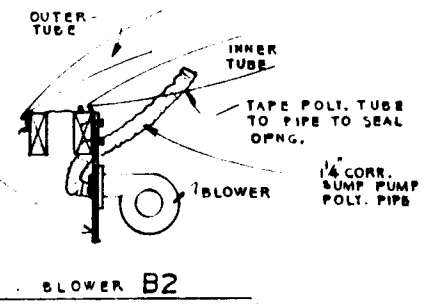
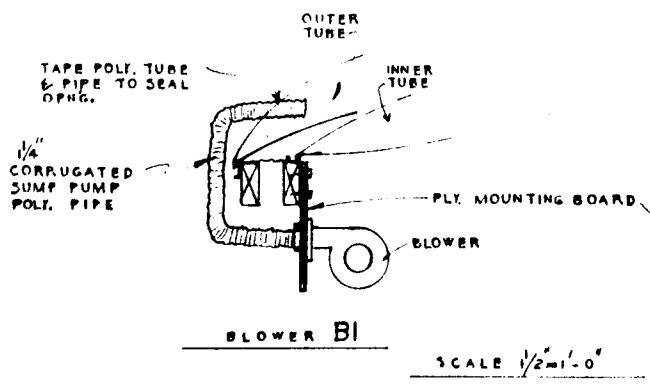
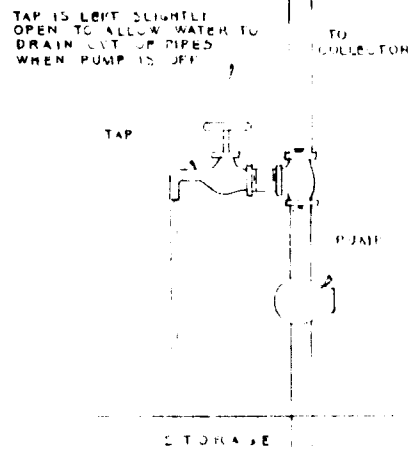
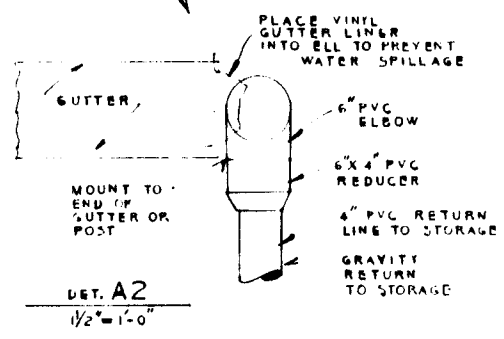
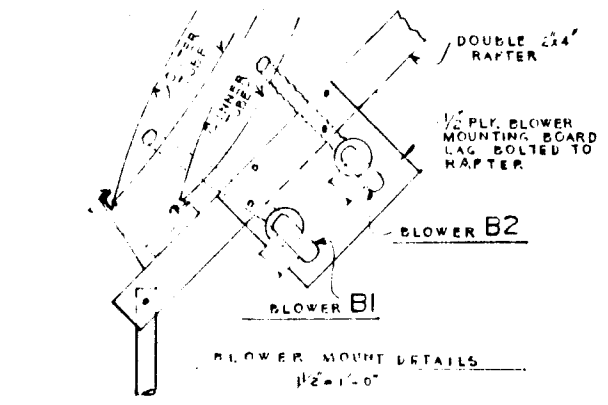
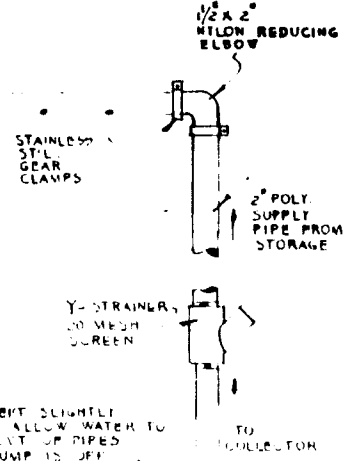
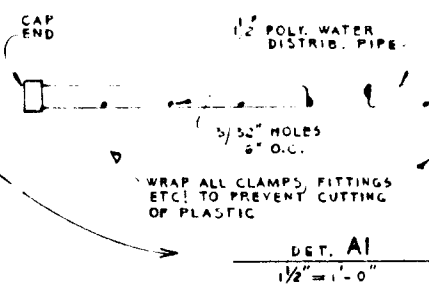
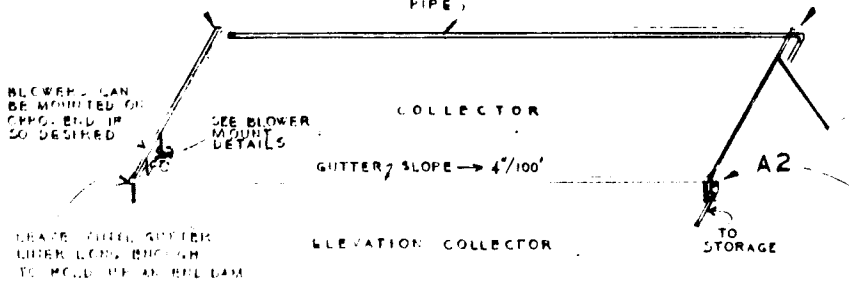

BLOWER INFO.

60 CFM @ FREE AIR & CUT OFF @ 0.5" H₂O
 MAX. INFLATION INNER TUBE 0.25' H₂O
 MAX. " OUTER " 0.20' H₂O

NOTE!
 MAINTAIN HIGHER PRESSURE IN INNER TUBE THAN OUTER TUBE IN ORDER TO GET A CONVEX SURFACE FOR WATER TO FLOW OVER

SCALE 1/2" = 1'-0"

WATER DISTRIBUTION & BLOWER MOUNTING DETAILS

EXPERIMENTAL		
TITLE SOLAR COLLECTOR II FIXED WOODEN		
RUTGERS - The State University COLLEGE of AGRICULTURE Dept. of Agricultural Engineering		
DESIGNED BY RUIZ	DRAWING NO. C-10954	SHEET 5 OF 5
DATE 11-7-78	SCALE	

REV. 7-17-78

MANUAL FOR FLOOR CONSTRUCTION

FLOOR SYSTEM DESIGN

The recommended floor depth and Rutgers type solar collector for various double-polyethylene-covered, air-inflated greenhouses with nighttime insulating blanket are as follows:

GREENHOUSE SIZE

	<u>Large</u>	<u>Medium</u>	<u>Small</u>
Greenhouse floor area	1 unit	1 unit	1 unit
Greenhouse heat loss area	1.33 unit	1.8 unit	2.5 unit
Suggested solar collector area	0.6 "	0.8 "	1.1 "
Suggested floor storage depth	7 inches	9 inches	12 inches
Suggested dry crushed stone or porous concrete depth	3 "	3 "	3 "
Total floor depth	10 "	12 "	15 "

The above system design will provide approximately 50% of the heat for a greenhouse in the New Jersey area when a thermal blanket has been installed that lowers the greenhouse overall U to 0.5 BTU/hr.ft²°F. The floor storage depth given is for the depth of crushed stone and water. An additional three inches of depth is required for dry crushed stone or porous concrete.

FLOOR SYSTEM CONSTRUCTION

Site Preparation

Depending on the solar collector location, the floor storage system can be built above or at grade level. The maximum height of the top of the floor is dependent on the height of the bottom of the solar collector gutter, since the water must be able to drain back into the floor storage by gravity. The maximum height of the solar collector gutter is 26 in., so the reasonable maximum height the top of the floor can be is about 6 in. below the gutter bottom. The ideal condition is to have level ground; then there will be no problem. The minimum suggested slope on the water return pipe from the solar collector water to the floor storage is 0.25 in./ft.

Details

Install foundation walls or anchor posts as directed by greenhouse supplier. When ordering the greenhouse, it may be necessary to order an anchor post that is 15 in. longer than the one normally supplied. This is necessary to satisfy minimum in-ground depth requirements.

The lumber to be used for framing the floor should be wolmanized tongue and groove or pressure treated with copper naphthenate. Pentachlorophenol and creosote cannot be used.

After the footing is installed, the treated tongue and groove 2x6 and 2x8 framing lumber is attached on the inside of the foundation, as shown in the partial elevation on the plan. The top of the frame must be level around the entire perimeter with the 2x6 and 2x8 joints staggered at the posts.

Depending on the type of polyethylene locking strip provided, a 2x4x 12 ft continuous support may be needed on the outside of the posts to attach the locking strip (Section @A). Once installed, a 2x4 flat should be nailed to this support and the top of the 2x6 tongue and groove board to close the air space caused by the posts (as shown in Section @A on the plan).

Insulation

Cut 2' wide strips of 3/4 in. to 1 in. thick rigid insulation board and fasten them to the inside surface of the floor frame with 1-1/2 in. roofing nails, burying part of the bottom half in the soil (Sections A & CC).

Install the horizontal floor insulation as shown in Detail E.

Liner

The liner, a single sheet of specially formulated 20-mil-thick vinyl, 4' wider and 8' longer than the greenhouse is rolled out and positioned on top of the insulation; take care not to disturb the sheets of insulation.

After the liner is rolled out and positioned, neatly fold the corners and staple them to the top of the floor frame, leaving slack in the vinyl so it will not be pulled on and torn when the stones are added. Staple through batten tape or nail through lath boards to connect the liner to the top of the floor frame around the entire perimeter, leaving slack so the liner won't tear. It is important to always leave slack in the vinyl liner at the corners so it will not be pulled tight and punctured while you load the crushed stone.

Corrugated 4in. Dia. Perforated Drain Pipe

The drain pipes are rolled out in the liner and installed on each side of the floor six inches away from the side walls as shown in the plan. The ends not going into the sump boxes are plugged with scrap plastic or rigid insulation board. Corrugated, perforated black polyethylene drain pipe is recommended.

Sump boxes

Corner sump boxes will vary in design and location depending on the location of the collector and back-up floor heating system being installed. The boxes are 2'x2'x11in. or 2'x3'x11in. and are situated with insulation pads between them and the liner, both on the sides and bottom. Typical design is shown in Detail B and Section CC. Cut only the holes required; the number varies according to what pipes enter.

Back-up Heating System

The back-up heating system is assembled in the floor on top of the vinyl liner. The plastic pipe should be 3/4in. i.d., 80 psi black polyethylene. It is installed with nylon fittings and stainless steel gear clamps. All joints are double clamped. The header system should be a reverse return type, as shown on the plan, and should start and end no more than 1' from the side walls with runs no more than 2' apart. Each loop can be a single piece of pipe that is curved 180° at one end and returned to the front, or two 90° nylon elbows and a 2' length of pipe can be used to make the loop. When installing, be sure not to kink the pipe or to get any stones or foreign matter in it. Also, be careful not to cut the liner with the gear clamps.

The main supply and return lines are 1-1/4in. i.d. pipe. Maximum water temperature from the boiler to the pipe should be 115°F and minimum 105°F. The flow rate should be 2.5 to 3 gpm for each 3/4in. pipe loop and no single loop should be longer than 200 ft with no more than 8 loops on one header.

IMPORTANT! Apply water pressure and test for leaks before adding stone!

If water hotter than 115°F must be used for the floor back-up heating system, then galvanized steel pipe must be used in the entire system. One-inch-diameter galvanized steel pipe can be laid in the floor on six-foot centers instead of the two foot required for the plastic pipe. The flow rate should be 8 gpm/loop.

Crushed Stone and Porous Concrete

The crushed stone is now added to the floor, taking care not to punch or tear any holes in the vinyl liner. The 4in.-diameter corrugated drain pipes should rest directly on the liner 6in. from the side walls. The back-up heating system pipes should be pulled up as the rock is being added so they are 2 to 3 inches above the vinyl liner. Do not place any rocks in the sump boxes.

Add rocks until the 8-8.5 inch level is reached. The rocks can be leveled if the floor is flooded to the desired level and the rocks spread out until the water and rock surfaces are the same. Pump out most of the water used as a leveling aid before pouring concrete cap.

If porous concrete is to be used, it can now be poured on the rocks and screeded off to the proper level. Do not work it with a trowel, as this will cause the top surface to seal up.

If no porous concrete is to be used, add more rocks or whatever is to be added, until there is at least 3in. of dry material between the top of the water and rock and the floor surface.

The floor installation is now complete.

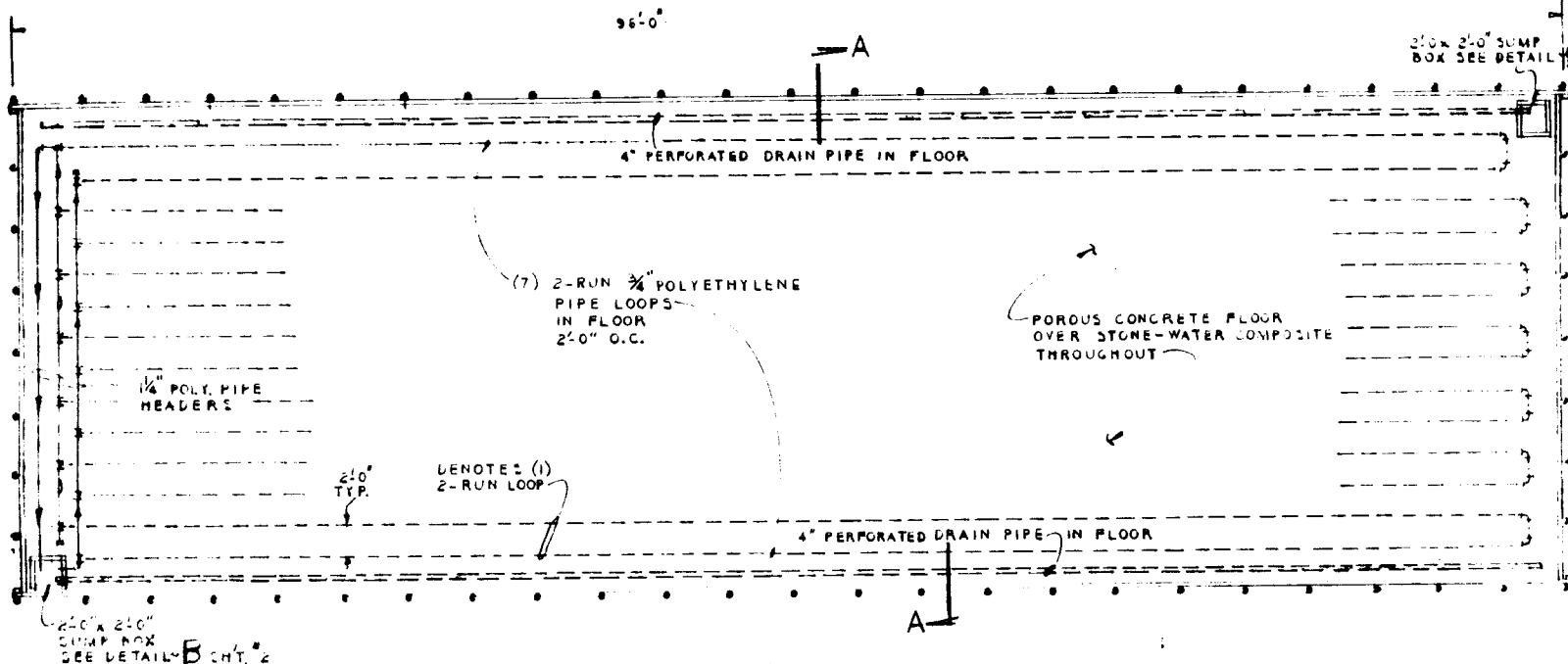

~ PLAN OF A TYPICAL 30' X 96' FLOOR HEATING GREENHOUSE FOUNDATION ~
SCALE 3/16" = 1'-0"

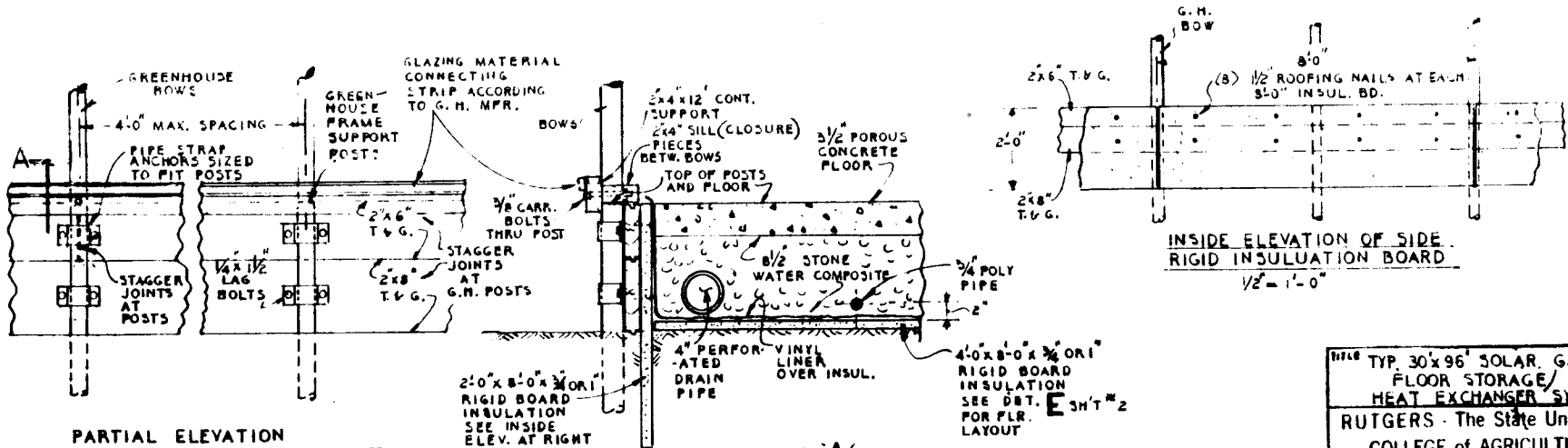

PARTIAL ELEVATION

SECTION @ 'A'
1/2" = 1'-0"

INSIDE ELEVATION OF SIDE RIGID INSULATION BOARD
1/2" = 1'-0"

TITLE TYP. 30' X 96' SOLAR. G.H. FLOOR STORAGE/HEAT EXCHANGER SYSTEM		
RUTGERS - The State University COLLEGE of AGRICULTURE Dept. of Agricultural Engineering		
DESIGN BY RUIZ	DRAWING NO. C-11054	SHEET 1 OF 2
DATE JULY 80	SCALE	

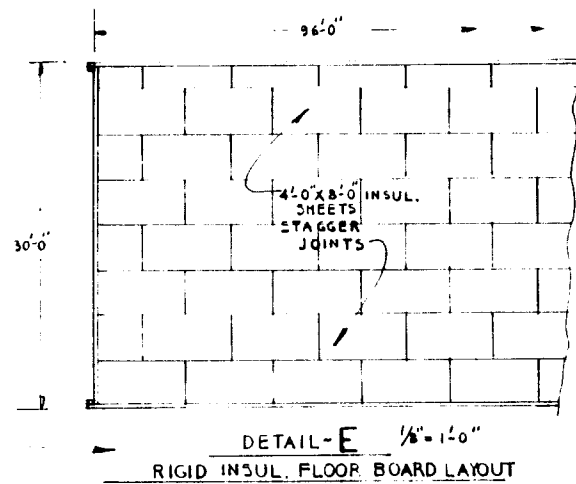
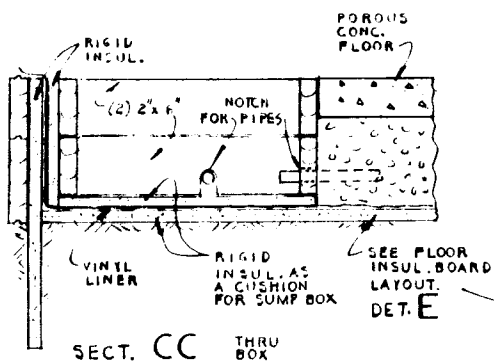
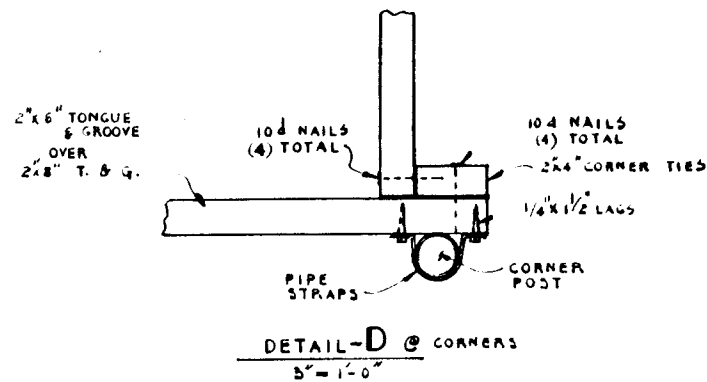
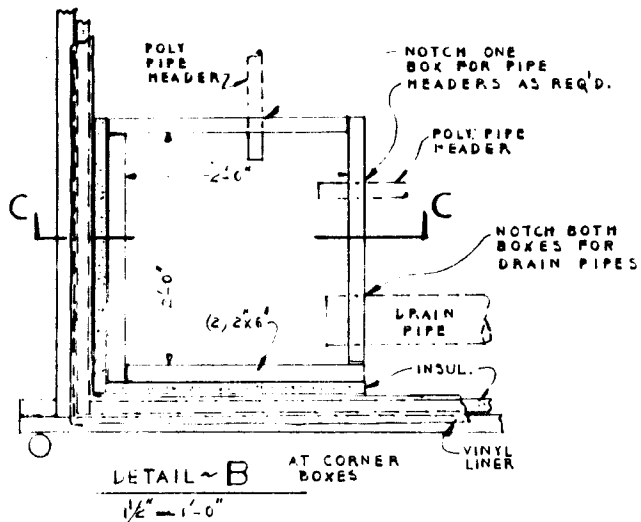

TITLE		
TYP. 30'x96' SOLAR G.H. FLOOR STORAGE/HEAT EXCHANGER SYSTEM		
RUTGERS - The State University		
COLLEGE of AGRICULTURE		
Dept. of Agricultural Engineering		
DRN BY	DRAWING NO.	SHEET 2 OF 2
DATE	C-11054	SCALE
JULY-80		